

External Holders

C1 ~ C33

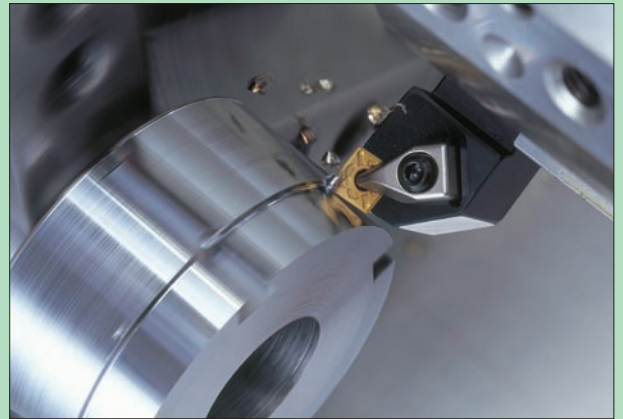

External Holders

	SEC-External Tool Holder Series	C2
	SEC-External Tool Identification Table	C4
	SumiTurn T-REX Tool Holders	C6
	DCLN Type/PCLN Type/PCBN Type Holders	C09
	PCFN Type Holders	C10
	DDJN Type/^{new} DDHN Type/^{new} DDNN Type Holders ...	C11
	PDJN Type Holders	C12
	PSSN Type/PSDN Type Holders	C13
	PSBN Type/PSKN Type Holders	C14
	ESBN Type/ESDN Type/ESKN Type Holders	C15
	ESSN Type Holders	C16
	DTGN Type/DTFN Type/PTGN Type Holders	C17
	PTTN Type/PTFN Type Holders	C18
	ETGN Type/ETAN Type Holders	C19
	ETFN Type/ETEN Type Holders	C20
	ETXN Type/MTJN Type/MTXN Type Holders	C21
	^{new} DVJN Type/^{new} DVVN Type/^{new} DVQN Type Holders ...	C23
	CVC Type/CVJ Type Holders	C24
	DWLN Type/PWLN Type/MWLN Type Holders	C25
	PRGC Type/PRDCN Type Holders	C27
	SVJC Type/SVVC Type/SVPC Type Holders	C28
	FP11 Type/FP14 Type/FP15 Type Holders	C29
	FP21 Type/FP22 Type/FP25 Type Holders	C30
	Tool Holders for Aluminum Wheel Turning	C31
	SEC-MV Type Copying Tool Holders	C32
	SEC-GD Type Copying Tool Holders	C33

T-REX Tool Holders

C N□□ Applicable Insert Holders

D N□□ Applicable Insert Holders

S N□□ Applicable Insert Holders

T N□□ Applicable Insert Holders

V N□□ Applicable Insert Holders

W N□□ Applicable Insert Holders

R C□□ Applicable Insert Holders

V C□□ Applicable Insert Holders

S P□□ Applicable Insert (w/o Hole) Holders

T P□□ Applicable Insert (w/o Hole) Holders

Aluminum Wheel Turning Holders

SEC- External Tool Holder Series



General Features

Since the development of the Top-Clamp SEC-2 type holders in 1959 and the cam-lock SEC-3 type the following year, Sumitomo Electric has had more than 40 years of experience in producing and developing indexable holders. Presently, Sumitomo Electric provides a wide variety of top quality external turning tools to satisfy any machining need with reliable and consistent performance.

SEC : Steady & Easy Clamp is the generic code for our indexable holders







TOOLING SELECTION

Application		General turning & facing		General turning & copying		General turning			
Clamping	Insert Type Series	80° Diamond Type		55° Diamond Type		60° Triangular Type			
		Screw Lock	SEC-MINI	SCLC →C56	SCAC →C56	SDJC →C52 SDJP →C55	SDAC →C52 SDAP →C55	STGC →C60	STAC →C60
—	—			SDNC →C52	—	—	—	—	—
Lever Lock	SEC-70 <small>⊗ Side lever locking system</small>	PCLC →C56	PCLN →C9	PDJC →C52	—	PTGN →C17	PTTN →C18	PTFN →C18	—
		PCBN →C9	PCFN →C10	PDJN →C12	—	—	—	—	—
Pin Lock	SEC-30	—	—	—	—	ETGN →C19	ETAN →C19	ETFN →C20	ETEN →C20
Double Lock	SEC-M SEC-D	DCLN →C9	DDJN →C11	DDHN →C11	DDNN →C11	DTGN →C17	DTFN →C17	MTJN →C21	MTXN →C21
		T-REX →C7	—	T-REX →C7	T-REX →C7	Top Clamp SEC-40	FP21/22 →C30	FP25 →C30	—

Performance Comparison Table

Series	Clamping System						Rake Angle		Clamp Rigidity	Handing	Index Accuracy	Chip Control	Economy	Legend
	P	E	C	M	S	D	Negative	Positive						
SumiTurn T-REX Tool Holders						○	○		◎	◎	◎	◎	<Clamping System> P : Lever Lock E : Pin Lock C : Top Clamp M : Pin & Top Clamp S : Screw Lock D : Double Lock	
SEC-D Type Holders						○	○		◎	◎	◎	◎	<Characteristics> ◎ : Excellent ○ : Very Good △ : Good	
SEC-70 Type Holders	○						○		◎	◎	◎	◎		
SEC-30 Type Holders		○					○		△	○	△	◎		
SEC-M Type Holders				○			○		◎	◎	○	○		
SEC-60 Type Holders				○			○		◎	○	◎	◎		
SUMIBORON PR Type Holders	○							○	◎	◎	◎	△		

TOOLING SELECTION

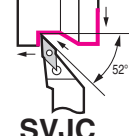
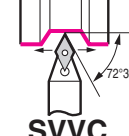
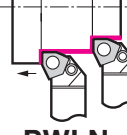
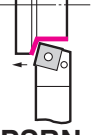
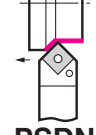
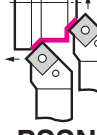
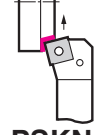
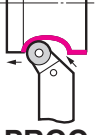
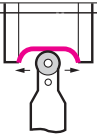
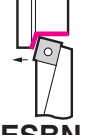
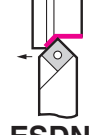
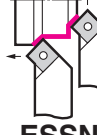
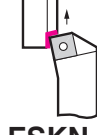
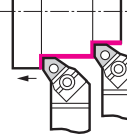
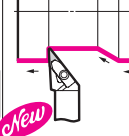
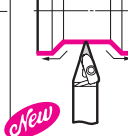
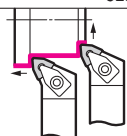
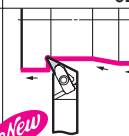
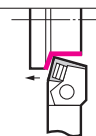
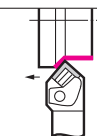
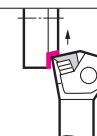
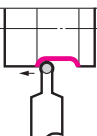
Application	Clamping	Insert Type Series	General turning	General turning & copying	General turning				Special turning	
			Trigon Type 	35° Diamond Type 	Square Type 				Round Type 	
Screw Lock	SEC-MINI	SEC-SV		 SVPC →C62 SVPP →C64	 SVLC →C62 SVLP →C64	 SSBC →C59				
					 SVJC →C28	 SVVC →C28				
Lever Lock	SEC-70		 PWLN →C25		 PSBN →C14	 PSDN →C13	 PSSN →C13	 PSKN →C14	 PRGC →C27	
										 PRDCN →C27
Pin Lock	SEC-30				 ESBN →C15	 ESDN →C15	 ESSN →C16	 ESKN →C15		
Double Lock	SEC-M SEC-D		 MWLN →C25	 DVJN →C23 <i>New</i>	 DVVN →C23 <i>New</i>					
			 DWLN →C25	 DVQN →C23 <i>New</i>		Top Clamp SEC-40 SEC-R	 FP11 →C29	 FP14 →C29	 FP15 →C29	 BNRN →L55

SEC- External Tool Identification Table

■ Catalogue Classification System For SEC-Tool Holders

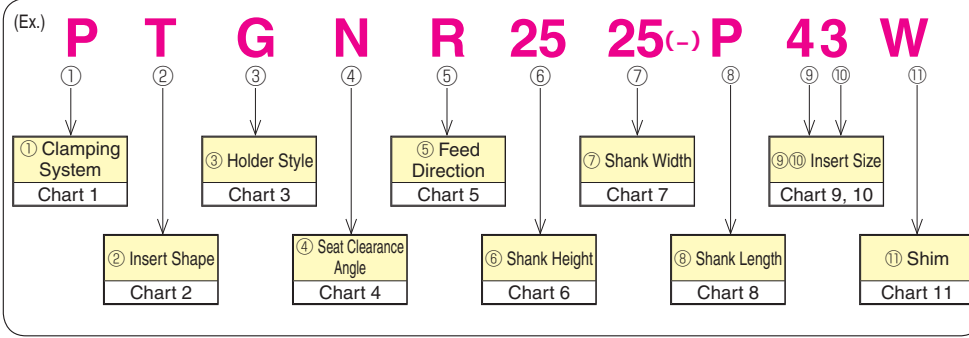

● Identification Example

PTGNR2525P43W

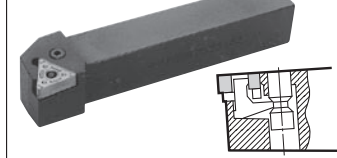

- Clamping: Lever lock system
- Shape: Triangular insert with 91° cutting angle
- Shank: H - 25 mm, W - 25 mm, L - 170 mm

Chart 1

① Clamping System					
Symbol	System	Structure	Symbol	System	Structure
C	Top Clamp		M	Top Clamp + Pin Lock	
D	Double Clamp		P	Lever Lock (Insert is supported by 2 faces)	
E	Pin Lock (Insert is supported by 1 face)		S	Screw Lock	

Chart 2

② Insert Shape			
Symbol	Insert Shape	Symbol	Insert Shape
A	Parallelogram 85°	M	Rhombic 86°
B	Parallelogram 82°	O	Octagonal
C	Diamond 80°	P	Pentagonal
D	Diamond 55°	R	Round
E	Diamond 75°	S	Square
F	Diamond 50°	T	Triangular
H	Hexagonal	V	Diamond 35°
K	Parallelogram 55°	W	Trigon
L	Rectangular		

Chart 4

④ Seat Clearance Angle	
Symbol	Relief Angle
A	3°
B	5°
C	7°
D	15°
E	20°
F	25°
G	30°
N	0°
P	11°
O	Special Angle

Chart 5

⑤ Feed Direction					
Symbol	Right Hand Feed	Symbol	Left Hand Feed	Symbol	Neutral Feed
R		L		N	

Chart 3

Holder Style (— Indicates major cutting edge)					
Symbol	Shape	Offset	Symbol	Shape	Offset
A		Nil	L		Yes
B		Nil	N		Nil
D		Nil	R		Yes
E		Nil	S		Yes
F		Yes	T		Yes
G		Yes	U		Yes
J		Yes	W		Yes
K		Yes	Y		Yes

Chart 6

⑥ Shank Height		⑦ Shank Width	
Symbol	Height (mm)	Symbol	Width (mm)
12	12	12	12
16	16	16	16
20	20	20	20
25	25	25	25
32	32	32	32
40	40	40	40
50	50	50	50

2 digits are used for each dimension in mm.

Chart 7

Chart 8

⑧ Shank Length	
Symbol	Length (mm)
F	80
H	100
K	125
M	150
N	160
P	170
Q	180
S	250
T	300
U	350

For some products, a hyphen is used instead of an alphabet.

Chart 9

⑨ Incribed Circle	
Symbol	Incribed Circle (mm)
3	9.525
4	12.70
5	15.875
6	19.05
8	25.40

For Round Inserts:

10	10
12	12
16	16
20	20
25	25
32	32

Chart 10

⑩ Insert Thickness	
Symbol	Thickness (mm)
2	3.18
3	4.76
4	6.35
5	7.94
6	9.52

Please refer to the following figures in case of round insert.

Chart 11

⑪ Shim	
Symbol	Shim
W	With
U	Without

Position of Cutting Point and Nose Radius

Cutting point position in relation to the nose radius

Tool Shapes			Dimensions (mm)			Tool Shapes			Dimensions (mm)		
Symbol	Shapes	Corner Shapes	R	X	Y	Symbol	Shapes	Corner Shapes	R	X	Y
A			0.4	0.291	—	K			0.4	0.024	0.089
			0.8	0.581	—				0.8	0.048	0.178
			1.2	0.872	—				1.2	0.072	0.268
			1.6	1.162	—				1.6	0.096	0.357
			2.4	1.743	—				2.4	0.143	0.535
B			0.4	0.089	0.024	L			0.4	0.040	0.040
			0.8	0.178	0.048				0.8	0.079	0.079
			1.2	0.268	0.072				1.2	0.119	0.119
			1.6	0.357	0.096				1.6	0.159	0.159
			2.4	0.535	0.143				2.4	0.238	0.238
D			0.4	0.164	0.164	N			0.4	0.463	0.263
			0.8	0.329	0.329				0.8	0.925	0.471
			1.2	0.493	0.493				1.2	1.388	0.707
			1.6	0.658	0.658				1.6	1.850	0.943
			2.4	0.986	0.986				2.4	2.776	1.414
E			0.4	0.396	0.229	S			0.4	0.164	0.164
			0.8	0.793	0.458				0.8	0.329	0.329
			1.2	1.190	0.687				1.2	0.493	0.493
			1.6	1.587	0.916				1.6	0.658	0.658
			2.4	2.381	1.374				2.4	0.986	0.986
F			0.4	—	0.291	T			0.4	0.396	0.229
			0.8	—	0.581				0.8	0.793	0.458
			1.2	—	0.872				1.2	1.190	0.687
			1.6	—	1.162				1.6	1.587	0.916
			2.4	—	1.743				2.4	2.381	1.374
G			0.4	0.291	—	U			0.4	0.253	0.058
			0.8	0.581	—				0.8	0.506	0.116
			1.2	0.872	—				1.2	0.759	0.175
			1.6	1.162	—				1.6	1.013	0.233
			2.4	1.743	—				2.4	1.519	0.350
J			0.4	0.344	0.033	Y			0.4	0.002	0.033
			0.8	0.687	0.079				0.8	0.005	0.066
			1.2	1.031	0.118				1.2	0.008	0.099
			1.6	1.375	0.157				1.6	0.011	0.132
			2.4	2.062	0.236				2.4	0.017	0.198

Nose radius position calculation

Calculation Formula (mm)			Values of "A" and "R" for the calculation of "B" (mm)					
Insert Shape	Formula		I.C. Number	"A" value	Nose R Code	Dimension	"R" value	
	Triangle	$B = 3/2A - R$	—	5	3.9688	0	0.2	0.203
	Square	$B = (\sqrt{2} - 1) \times (A/2 - R)$	—	6	4.7625	1	0.4	0.397
	Rhombic	$B = (1/\sin(\theta/2) - 1) \times (A/2 - R)$	—	7	5.5562	2	0.8	0.794
			2	8	6.3500	3	1.2	1.191
			—	0	7.9375	4	1.6	1.588
			3	—	9.5250	6	2.4	2.389
			4	—	12.7000			
			5	—	15.8750			
			6	—	19.0500			
			8	—	25.4000			

SumiTurn T-REX Tool Holders

External Holders

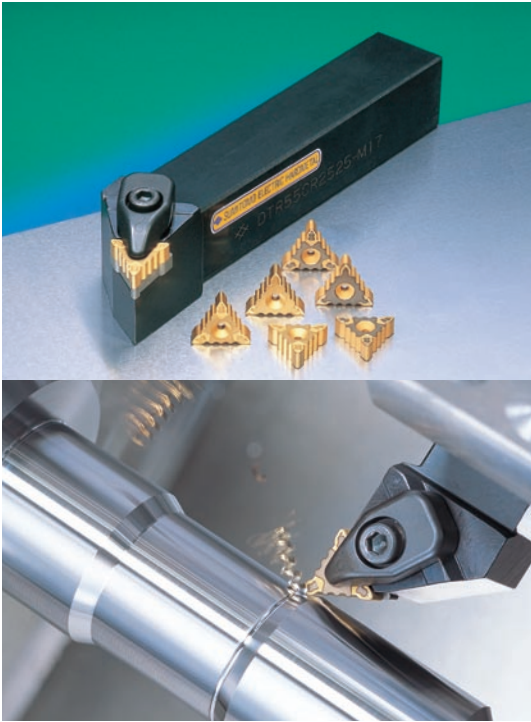

SumiTurn

General Features

SumiTurn T-REX series utilises a unique design triangular insert for cost effective copy turning.



Characteristics ● 55° Included Angle

1.5 times more cutting edges as compared to DNMG inserts!

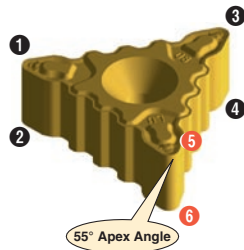

Extra-Strong Clamping

Extra strong and rigid clamping with unique clamp on lock and serration insert design.

- Prevents the insert from shifting during copying
- Reliability even in interrupted machining

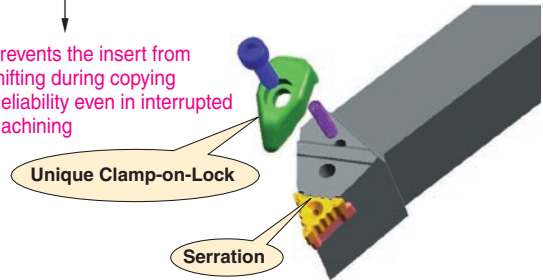

Application Examples

● SCr420 (Shaft)

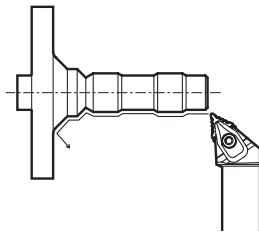

Cutting Conditions

Insert: TRM551708-GU, AC2000
V=150m/min, f=0.25mm/rev, d<2.0mm, WET

Results

Based on the increased number of corners, a 33% cost reduction was achieved!

Tool Cost Comparison

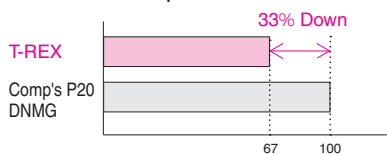

● SCM420 (Gear)

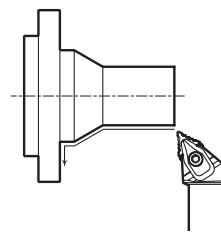

Cutting Conditions-

Insert: TRM551708-LU, AC700G
V=220m/min, f=0.20 ~ 0.30mm/rev, d=1.0mm, WET

Results

Based on the increased number of corners, a 50% cost reduction was achieved!

Tool Cost Comparison

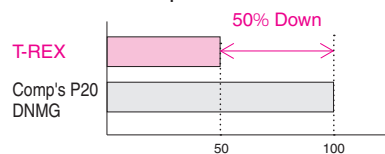

SumiTurn T-REX Tool Holders

External Holders

External Turning & Copying

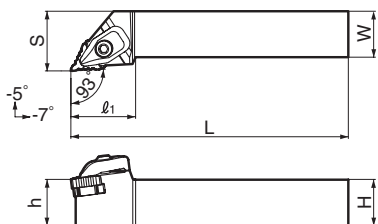
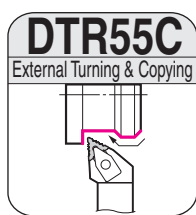

Holder

Above figures show right hand tools.

Cat. No.	Stock		Dimensions (mm)					
	R	L	H	W	L	S	h	ℓ_1
DTR55C R/L2020-K17	●	●	20	20	125	25	20	35
DTR55C R/L2525-M17	●	●	25	25	150	32	25	35

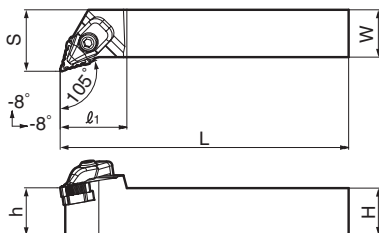

New

Above figures show right hand tools.

Cat. No.	Stock		Dimensions (mm)					
	R	L	H	W	L	S	h	ℓ_1
DTR55Q R/L2020-K17	●	●	20	20	125	28.5	20	35
DTR55Q R/L2525-M17	●	●	25	25	150	32	25	35

Internal Copying

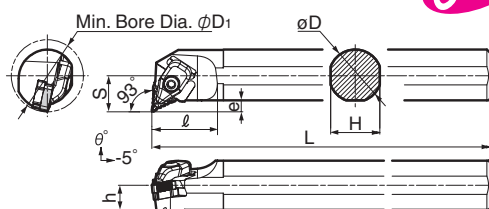
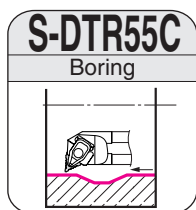

New

Holder

Cat. No.	Stock	Min Bore	Dimensions (mm)							
			ϕD	H	L	S	ℓ_1	θ	e	h
S32S-DTR55CR-17	●	44	32	30	250	22	40	-12°	7	15
S40T-DTR55CR-17	●	50	40	37	300	25	40	-10°	6.2	18.5

Application Precautions

●Depth-of-cut (D.O.C.)

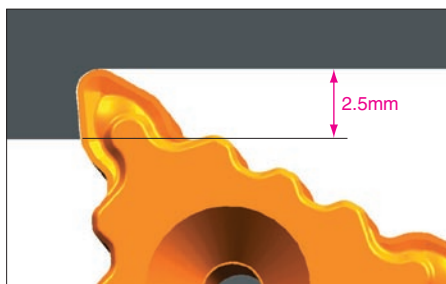

Maximum D.O.C. should be 2.5mm

●Cutting Edge Angle

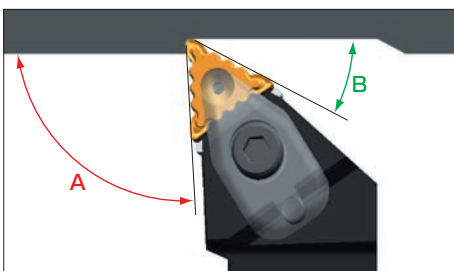

Holder Cat. No.	A	B	Note
DTR55C Type	93°	27°	Approach angle of major cutting edge is 95.5°.
DTR55Q Type	105°	15°	Approach angle of major cutting edge is 107.5°.

Parts

Clamp	Spring	Cap Screw	Shim
TRCP3	S-SP4-20	BX0520	TRW5505
Screw	Wrench	Wrench	
BFTX0307N	TSW040	TRX10(※)	

※ item is sold separately.

●T-REX Insert and Holders Identification

Insert

TRM	55	17	08	-GU
T-REX	Apex Angle	Insert Size	Nose Radius	Breaker Name

External Holder

DTR	55	C	R	2525	-M	17
T-REX	Apex Angle	Approach Angle Code	Feed Direction	Shank Size	Shank Length	Insert Size

Boring Bar

S	32	S	-DTR	55	C	R	-17
Shank Material	Shank Diameter	Shank Length	T-REX	Apex Angle	Approach Angle Code	Feed Direction	Insert Size

Note: Approach Angle Code

C·····93° (95.5° for major cutting edge)

Q·····105° (107.5° for major cutting edge)

●Insert Clamping

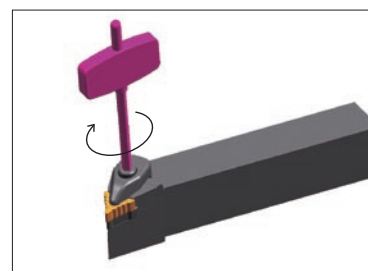

Please use the attached special wrench TSW040 (3.5-4.5Nm torque is recommended).

SumiTurn T-REX Tool Holders

External Holders

Insert

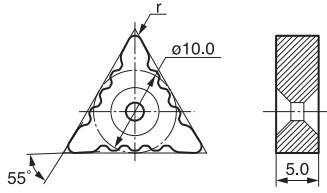

Application P steel M Stainless Steel

	Cat. No.	Nose Radius, r	Coated Carbide					Coated Cermet	
			AC700G	AC2000	AC3000	AC610M <i>New</i>	AC630M <i>New</i>	T2000Z <i>New</i>	T3000Z <i>New</i>
Fine Finishing <i>New</i>	TRM551704-FL	0.4		●				●	●
	551708-FL	0.8		●				●	●
Finishing <i>New</i>	TRM551704-LU	0.4	●	●	●			●	●
	551708-LU	0.8	●	●	●			●	●
	551712-LU	1.2	●	●	●			●	●
Medium Cut	TRM551704-SU	0.4	●	●	●	○	●	●	●
	551708-SU	0.8	●	●	●	○	●	●	●
	551712-SU	1.2	●	●	●	○	●	●	●
Medium Cut	TRM551704-GU	0.4	●	●	●		●		
	551708-GU	0.8	●	●	●		●		
	551712-GU	1.2	●	●	●		●		

Chipbreaker Application Range

Main Chipbreakers

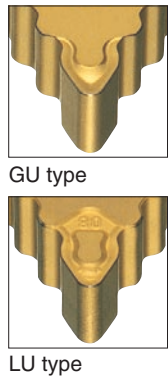
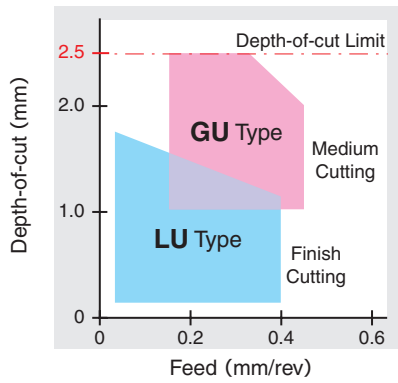

Finishing Sub-Chipbreakers

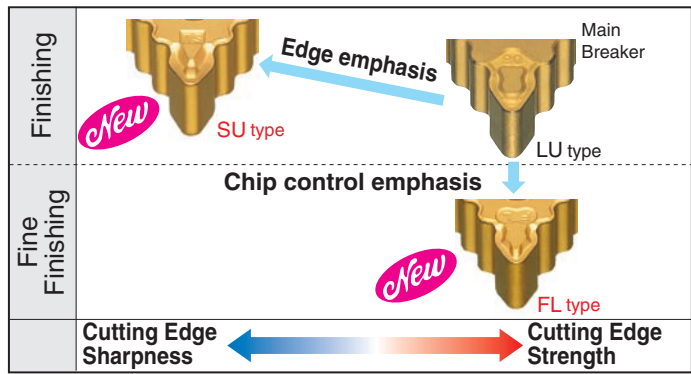

Application Range by Grade

Grade of Insert		AC700G	AC2000	AC3000	AC610M	AC630M	T2000Z	T3000Z
Classification of Grades		Coated Carbide	Coated Carbide	Coated Carbide	Coated Carbide	Coated Carbide	Coated Cermet	Coated Cermet
Workpiece Material	Low-carbon Steel	200 - 400	150 - 350	120 - 300	180 - 350	120 - 300	100 - 400	100 - 400
	General Steel & Alloy Steel	150 - 300	100 - 250	80 - 200	180 - 280	80 - 230	100 - 300	100 - 250
	Stainless Steel			50 - 150	130 - 210	100 - 160		
Usage	Finishing	○	○	○	◎	○	◎	◎
	Medium Cut	○	◎	○	○	◎	○	○
	Interrupted Cut		○	◎		○		○

◎ : Optimum ○ : Good

SEC-External Tool Holders DCLN/PCLN/PCBN Type

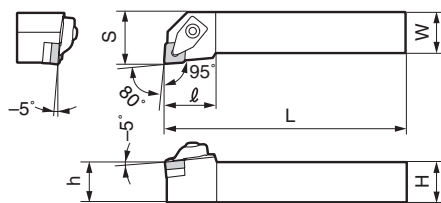
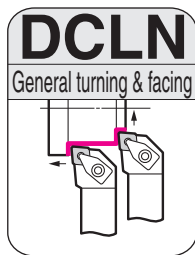

SEC-D Type Holders

General turning and facing
Double Lock

Parts

※ Item is sold separately.

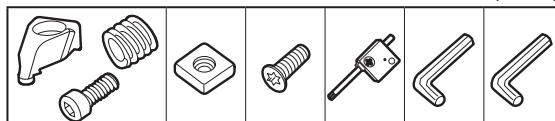

Holder

Above figures show right hand tools.

Sumitomo Cat. No.	Stock		Dimensions (mm)						Applicable Insert		Clamp Set	Shim	Shim Screw	Wrench	Top Wrench	Bottom Wrench
	R	L	H	W	L	S	h	l	Cat. No.	Featured page						
DCLN R/L2020K12	●	●	20	20	125	25	20	32	CN□□1204	B15~	SCP-2	CNS1204	BFTX0409N	TRX15 (※)	LH040	LH025
DCLN R/L2525M12	●	●	25	25	150	32	25	32								

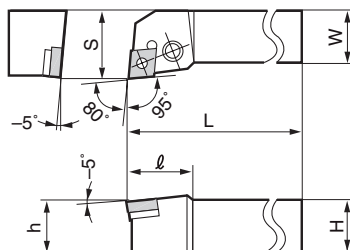
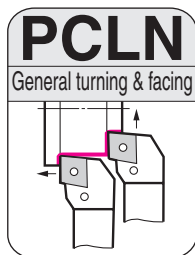

SEC-70 Type Tool Holders

General turning and facing
Lever Lock

Parts

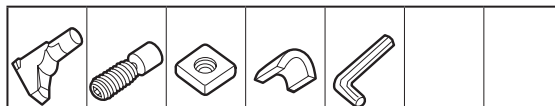

Holder

Above figures show right hand tools.

Sumitomo Cat. No.	Stock		Dimensions (mm)						Applicable Insert		Lever Pin	Clamp Bolt	Shim	Shim Pin	Wrench		
	R	L	H	W	L	S	h	l	Cat. No.	Featured page							
PCLN R/L1616-32	●	●	16	16	100	20	16	20	CN□□0903	B14	LCL3	LCS3	LSC32	LSP3	LH025		
PCLN R/L2020-33	●	●	20	20	125	25	20	20	CN□□0904	B15	LCL3	LCS3	LSC317	LSP3	LH025		
PCLN R/L2525-33	●	●	25	25	150	32	25	20									
PCLN R/L2020-43	●	●	20	20	125	25	20	28									
PCLN R/L2520-43	●	●	25	20	150	25	25	28									
PCLN R/L2525-43	●	●	25	25	150	32	25	28	CN□□1204	B15~	LCL4	LCS4	LSC32	LSP4	LH030		
PCLN R/L3225-43	●	●	32	25	170	32	32	28									
PCLN R/L3232-43	●	●	32	32	170	40	32	28									
PCLN R/L2525-54	●	●	25	25	150	32	25	33									
PCLN R/L3225-54	●	●	32	25	170	32	32	33	CN□□1606	B20~	LCL5	LCS5	LSC53	LSP5	LH030		
PCLN R/L3232-54	●	●	32	32	170	40	32	33									
PCLN R/L3225-64	●	●	32	25	170	32	32	38									
PCLN R/L3232-64	●	●	32	32	170	40	32	38	CN□□1906	B21~	LCL6	LCS6	LSC63	LSP6	LH040		
PCLN R/L4040-64	●	●	40	40	200	50	40	38									

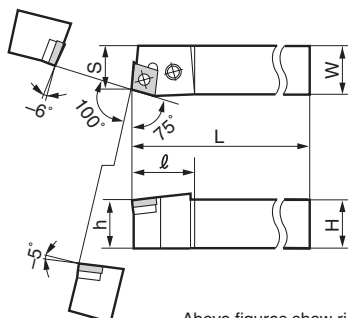
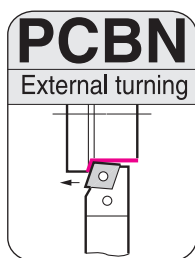

SEC-70 Type Tool Holders

External turning
Lever Lock

Parts

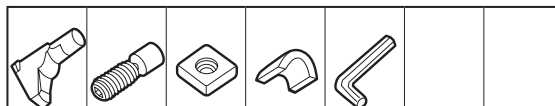

Holder

Above figures show right hand tools.

Sumitomo Cat. No.	Stock		Dimensions (mm)						Applicable Insert		Lever Pin	Clamp Bolt	Shim	Shim Pin	Wrench		
	R	L	H	W	L	S	h	l	Cat. No.	Featured page							
PCBN R/L2020-43	●	●	20	20	125	17	20	27									
PCBN R/L2520-43	●	●	25	20	150	17	25	27	CN□□1204	B15~	LCL4	LCS4	LSC42	LSP4	LH030		
PCBN R/L2525-43	●	●	25	25	150	22	25	27									
PCBN R/L3225-43	●	●	32	25	170	22	32	27									
PCBN R/L2525-54	●	●	25	25	150	22	25	33									
PCBN R/L3225-54	●	●	32	25	170	22	32	33	CN□□1606	B20~	LCL5	LCS5	LSC53	LSP5	LH030		
PCBN R/L3232-54	●	●	32	32	170	27	32	33									
PCBN R/L3232-64	●	●	32	32	170	27	32	38									
PCBN R/L4040-64	●	●	40	40	200	35	40	38	CN□□1906	B21~	LCL6	LCS6	LSC63	LSP6	LH040		

SEC-External Tool Holders PCFN Type

External Holders

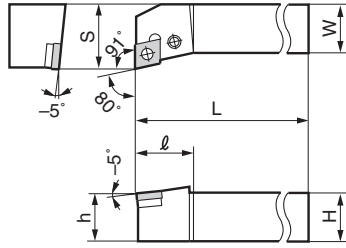
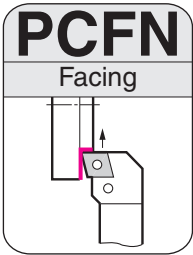

SEC- 70 Type Holders

Facing
Lever Lock

Parts

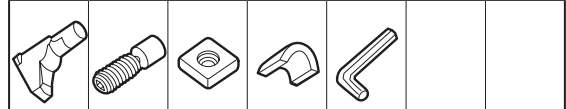

Holder

Above figures show right hand tools.

Sumitomo Cat. No.	Stock		Dimensions (mm)						Applicable Insert		Lever Pin	Clamp Bolt	Shim	Shim Pin	Wrench		
	R	L	H	W	L	S	h	l	Cat. No.	Featured page							
PCFN R/L2020-43	●	●	20	20	125	25	20	28	CN□□1204	B15~	LCL4	LCS4	LSC42	LSP4	LH030		
PCFN R/L2520-43			25	20	150	25	25	28									
PCFN R/L2525-43	●	●	25	25	150	32	25	28									
PCFN R/L3225-43			32	25	170	32	32	28									

Insert

DCLN/PCLN/PCBN/PCFN Type

Recommended Inserts

- Please also refer to the selection guide for inserts. (B4~)
- Some combinations need to be made-to-order or cannot be manufactured.

Applications Conditions	P (Steel)			M (Stainless Steel)			K (Cast Iron)		
	Finishing	Medium Cut	Roughing	Finishing	Medium Cut	Roughing	Finishing	Medium Cut	Roughing
Continuous Cut	SU AC700G	GU AC700G	MU AC700G	SU AC630M	EX AC630M	MU AC630M	SUMIBORON BN700	UZ AC410K	UZ AC410K
General Purpose	SU AC2000	GU AC2000	MU AC2000	SU AC630M	EX AC630M	MU AC630M	SUMIBORON BN700	UX AC410K	UX AC700G
Interrupted Cut	SX AC3000	UX AC3000	MU AC3000	SU AC630M	GU AC3000	MU AC3000	SUMIBORON BN700	UX AC700G	No Breaker AC700G

Applications Conditions	N (Non-ferrous)	H (Hardened Steel)	
	—	High-speed Finish	Finishing
Continuous Cut	SUMIDIA DA2200	SUMIBORON BNC100, BNX10	SUMIBORON BNC200, BN250
General Purpose	SUMIDIA DA2200	SUMIBORON BNC100, BNX20	SUMIBORON BNC200, BN250
Interrupted Cut	SUMIDIA DA2200	SUMIBORON BNX25	SUMIBORON BNC300, BN350

Featured page

	Coated Carbide Coated Cermet Cermet Carbide Ceramics	SUMIBORON SUMIDIA
CN□□0903○○	B14	—
CN□□0904○○	B15	—
CN□□1204○○	B15~17	B18~19
CN□□1606○○	B20~21	—
CN□□1906○○	B21~22	—

SEC-External Tool Holders DDJN/DDHN/DDNN Type

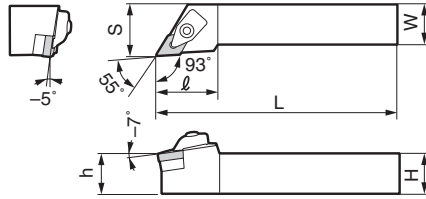
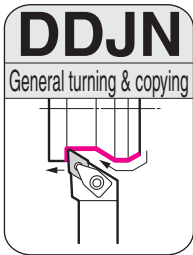

SEC- D Type Holders

General turning and copying
Double Lock

Holder

Above figures show right hand tools.

Sumitomo Cat. No.	Stock		Dimensions (mm)						Applicable Insert	
	R	L	H	W	L	S	h	l	Cat. No.	Featured page
DDJN R/L2020K15	●	●	20	20	125	25	20	20	DN□□1504	B24~
DDJN R/L2525M15	●	●	25	25	150	32	25	32		
DDJN R/L2525M15E	●	●	25	25	150	32	25	38	DN□□1506	B29~

Parts

※Item is sold separately.

Clamp Set	Shim	Shim Screw	Wrench	Top Wrench	Bottom Wrench
SCP-2	DNS1504 DNS1506	BFTX0409N	TRX15 (※)	LH040	LH025

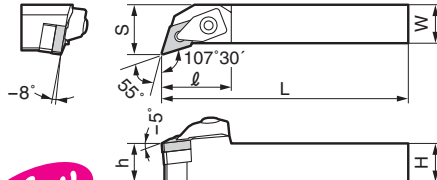
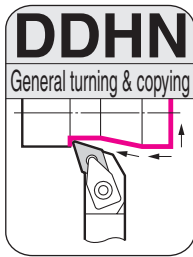

New

SEC- D Type Holders

General turning and copying
Double Lock

Holder

Above figures show right hand tools.

Sumitomo Cat. No.	Stock		Dimensions (mm)						Applicable Insert	
	R	L	H	W	L	S	h	l	Cat. No.	Featured page
DDHN R/L2020K15	●	●	20	20	125	25	20	35	DN□□1504	B24~
DDHN R/L2525M15	●	●	25	25	150	32	25	35		

Parts

※Item is sold separately.

Clamp Set	Shim	Shim Screw	Wrench	Top Wrench	Bottom Wrench
SCP-2	DNS1504	BFTX0409N	TRX15 (※)	LH040	LH025

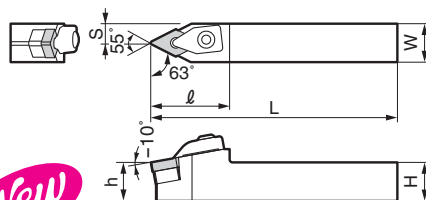
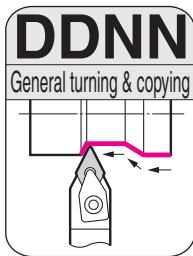

New

SEC- D Type Holders

General turning and copying
Double Lock

Holder

Sumitomo Cat. No.	Stock	Dimensions (mm)						Applicable Insert	
		H	W	L	S	h	l	Cat. No.	Featured page
DDNN 2020K15	●	20	20	125	10.5	20	40	DN□□1504	B24~
DDNN 2525M15	●	25	25	150	13	25	40		

Parts

※Item is sold separately.

Clamp Set	Shim	Shim Screw	Wrench	Top Wrench	Bottom Wrench
SCP-2	DNS1504	BFTX0409N	TRX15 (※)	LH040	LH025

SEC-External Tool Holders PDJN Type

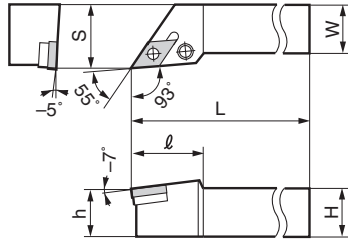
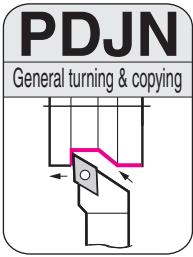

SEC-70 Type Tool Holders

General turning and copying
Lever Lock

Parts

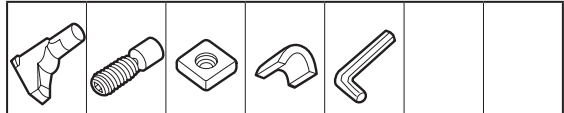

Holder

Above figures show right hand tools.

Sumitomo Cat. No.	Stock		Dimensions (mm)						Applicable Insert		Lever Pin	Clamp Bolt	Shim	Shim Pin	Wrench
	R	L	H	W	L	S	h	l	Cat. No.	Featured page					
PDJN R/L2020-33	●	●	20	20	125	25	20	25	DN□□1104	B24~	LCL3	LCS3	LSD317	LSP3	LH025
PDJN R/L2525-33	●	●	25	25	150	32	25	25							
PDJN R/L2020-43	●	●	20	20	125	25	20	35	DN□□1504	B24~	LCL4	LCS4	LSD42	LSP4	LH030
PDJN R/L2525-43	●	●	25	25	150	32	25	35							
PDJN R/L3225-43			32	25	170	32	32	35							
PDJN R/L3232-43	●	●	32	32	170	40	32	35							
PDJN R/L2525-44	●	●	25	25	150	32	25	35	DN□□1506	B29~	LCL4	LCS4	LSD42	LSP4	LH030
PDJN R/L3225-44			32	25	170	32	32	35							
PDJN R/L3232-44			32	32	170	40	32	35							

Insert

DDJN/DDHN/DDNN/PDJN Type

Recommended Inserts

- Please also refer to the selection guide for inserts. (B4~)
- Some combinations need to be made-to-order or cannot be manufactured.

Applications Conditions	P (Steel)			M (Stainless Steel)			K (Cast Iron)		
	Finishing	Medium Cut	Roughing	Finishing	Medium Cut	Roughing	Finishing	Medium Cut	Roughing
Continuous Cut	SU AC700G	GU AC700G	MU AC700G	SU AC630M	EX AC630M	MU AC630M	SUMIBORON BN700	UZ AC410K	UZ AC410K
General Purpose	SU AC2000	GU AC2000	MU AC2000	SU AC630M	EX AC630M	MU AC630M	SUMIBORON BN700	UX AC410K	UX AC700G
Interrupted Cut	SX AC3000	UX AC3000	MU AC3000	SU AC630M	GU AC3000	MU AC3000	SUMIBORON BN700	UX AC700G	No Breaker AC700G

Applications Conditions	N (Non-ferrous)	H (Hardened Steel)	
	—	High-speed Finish	Finishing
Continuous Cut	SUMIDIA DA2200	SUMIBORON BNC100, BNX10	SUMIBORON BNC200, BN250
General Purpose	SUMIDIA DA2200	SUMIBORON BNC100, BNX20	SUMIBORON BNC200, BN250
Interrupted Cut	SUMIDIA DA2200	SUMIBORON BNX25	SUMIBORON BNC300, BN350

Featured page

	Coated Carbide Coated Cermet Cermet Carbide Ceramics	SUMIBORON SUMIDIA
DN□□1104○○	B24	—
DN□□1504○○	B24~27	B27~28
DN□□1506○○	B29~30	B30

SEC-External Tool Holders PSSN/PSDN Type

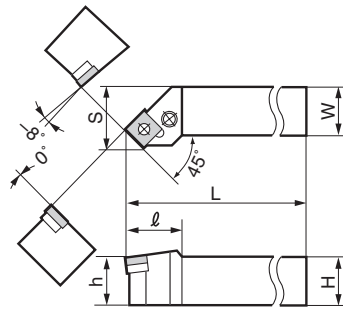
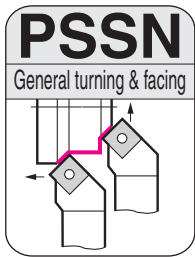

SEC-70 Type Tool Holders

General turning and facing
Lever Lock

Holder

Above figures show right hand tools.

Sumitomo Cat. No.	Stock		Dimensions (mm)						Applicable Insert		Lever Pin	Clamp Bolt	Shim	Shim Pin	Wrench		
	R	L	H	W	L	S	h	ℓ	Cat. No.	Featured page							
PSSN R/L1616-32	●	●	16	16	100	20	16	22	SN□□0903	B35	LCL3	LCS3	LSS32	LSP3	LH025		
PSSN R/L2020-43	●	●	20	20	125	25	20	30	SN□□1204	B36~	LCL4	LCS4	LSS42	LSP4	LH025		
PSSN R/L2520-43			25	20	150	25	25	30									
PSSN R/L2525-43	●	●	25	25	150	32	25	30									
PSSN R/L3225-43			32	25	170	32	32	30									
PSSN R/L3232-43			32	32	170	40	32	30	SN□□1506	B40	LCL5	LCS5	LSS53	LSP5	LH030		
PSSN R/L3225-54			32	25	170	32	32	40									
PSSN R/L3232-54	●	●	32	32	170	40	32	40	SN□□1906	B41~	LCL6	LCS6	LSS63	LSP6	LH040		
PSSN R/L3232-64	●	●	32	32	170	40	32	40									
PSSN R/L4040-64			40	40	200	50	40	40									

Parts

--	--	--	--	--	--	--

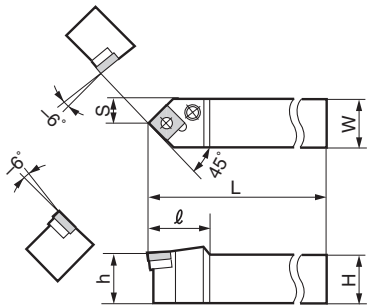
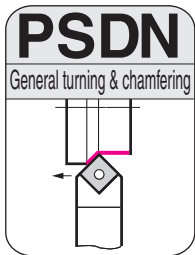

SEC-70 Type Tool Holders

General turning and chamfering
Lever Lock

Holder

Sumitomo Cat. No.	Stock	Dimensions (mm)						Applicable Insert		Lever Pin	Clamp Bolt	Shim	Shim Pin	Wrench		
		H	W	L	S	h	ℓ	Cat. No.	Featured page							
PSDNN 1616-32	●	16	16	100	8.0	16	22	SN□□0903	B35	LCL3	LCS3	LSS32	LSP3	LH025		
PSDNN 2020-43	●	20	20	125	10.0	20	30	SN□□1204	B36~	LCL4	LCS4	LSS42	LSP4	LH025		
PSDNN 2520-43		25	20	150	10.0	25	30									
PSDNN 2525-43	●	25	25	150	12.5	25	30									
PSDNN 3225-43		32	25	170	12.5	32	30									
PSDNN 3232-43	●	32	32	170	16.0	32	40	SN□□1506	B40	LCL5	LCS5	LSS53	LSP5	LH030		
PSDNN 3225-54		32	25	170	12.5	32	40									
PSDNN 3232-54		32	32	170	16.0	32	40	SN□□1906	B41~	LCL6	LCS6	LSS63	LSP6	LH040		
PSDNN 3232-64	●	32	32	170	16.0	32	40									
PSDNN 4040-64		40	40	200	20.0	40	40									

Parts

--	--	--	--	--	--	--

SEC-External Tool Holders PSBN/PSKN Type

External Holders

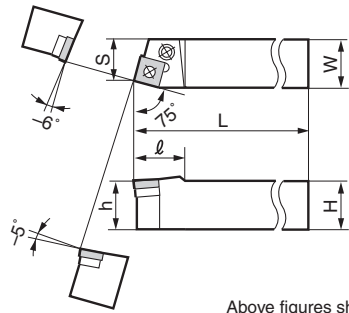
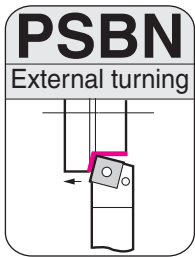

SEC-70 Type Tool Holders

External turning
Lever Lock

Holder

Above figures show right hand tools.

Sumitomo Cat. No.	Stock		Dimensions (mm)						Applicable Insert		Lever Pin	Clamp Bolt	Shim	Shim Pin	Wrench		
	R	L	H	W	L	S	h	ℓ	Cat. No.	Featured page							
PSBN R/L1616-32	●	●	16	16	100	13	16	22	SN□□0903	B35	LCL3	LCS3	LSS32	LSP3	LH025		
PSBN R/L2020-43	●	●	20	20	125	17	20	28	SN□□1204	B36~	LCL4	LCS4	LSS42	LSP4	LH030		
PSBN R/L2520-43			25	20	150	17	25	28									
PSBN R/L2525-43	●	●	25	25	150	22	25	28									
PSBN R/L3225-43			32	25	170	22	32	28	SN□□1506	B40	LCL5	LCS5	LSS53	LSP5	LH030		
PSBN R/L3232-43			32	32	170	27	32	35									
PSBN R/L3225-54			32	25	170	22	32	35	SN□□1906	B41	LCL6	LCS6	LSS63	LSP6	LH040		
PSBN R/L3232-54	●	●	32	32	170	27	32	35									
PSBN R/L3232-64	●	●	32	32	170	27	32	40	SN□□2507	B42	LCL8	LCS8	LSS84	LSP8	LH050		
PSBN R/L4040-64			40	40	200	35	40	40									
PSBN R/L5050-85			50	50	250	43	50	50									

Parts

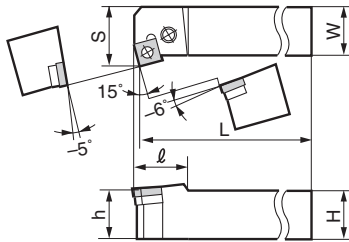
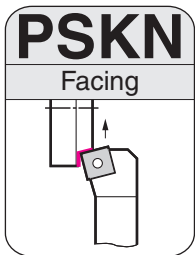
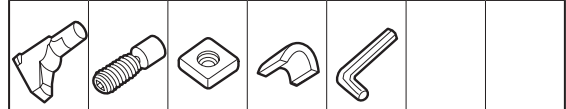

SEC-70 Type Tool Holders

Facing
Lever Lock

Holder

Above figures show right hand tools.

Sumitomo Cat. No.	Stock		Dimensions (mm)						Applicable Insert		Lever Pin	Clamp Bolt	Shim	Shim Pin	Wrench		
	R	L	H	W	L	S	h	ℓ	Cat. No.	Featured page							
PSKN R/L1616-32	●	●	16	16	100	20	16	20	SN□□0903	B35	LCL3	LCS3	LSS32	LSP3	LH025		
PSKN R/L2020-43	●	●	20	20	125	25	20	26	SN□□1204	B36~	LCL4	LCS4	LSS42	LSP4	LH030		
PSKN R/L2520-43			25	20	150	25	25	26									
PSKN R/L2525-43	●	●	25	25	150	32	25	26									
PSKN R/L3225-43			32	25	170	32	32	26	SN□□1506	B40	LCL5	LCS5	LSS53	LSP5	LH030		
PSKN R/L3232-43			32	32	170	32	32	26									
PSKN R/L3225-54			32	25	170	32	32	32	SN□□1906	B41	LCL6	LCS6	LSS63	LSP6	LH040		
PSKN R/L3232-54			32	32	170	32	32	32									
PSKN R/L3232-64	●	●	32	32	170	40	32	36	SN□□2507	B42	LCL8	LCS8	LSS84	LSP8	LH050		
PSKN R/L4040-64			40	40	200	50	40	36									
PSKN R/L5050-85			50	50	250	60	50	44									

Parts

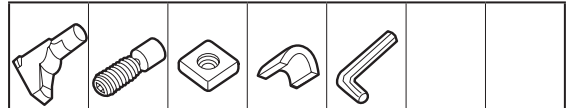

Note: when using right/left handed type inserts, holder and insert are opposite handed.

SEC-External Tool Holders ESBN/ESDN/ESKN Type

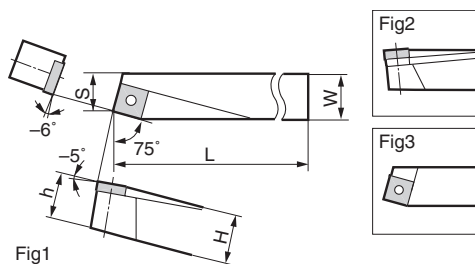
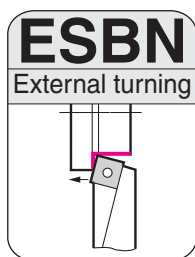

SEC-30 Type Tool Holders

External turning
Pin Lock

Parts

Pin	Shim	Wrench				
P321US	-					
P322US	-					
P432U	-					
P433U	-					
P433W	ESS42	KY40				
P434U	-					
P434W	ESS42					
P434U	-					
P434W	ESS42					

Holder

Above figures show right hand tools.

Sumitomo Cat. No.	Stock		Dimensions (mm)					Fig	Applicable Insert		Pin	Shim	Wrench			
	R	L	H	W	L	S	h		Cat. No.	Featured page						
ESBN R/L1212	●	●	12	12	80	9.5	11.5	1	SN□□0903	B35	P321US	-				
ESBN R/L1616H32			16	16	100	13	15.5	1			P322US	-				
ESBN R/L1616H43			16	16	100	13	15.5	3			P432U	-				
ESBN R/L2020			20	20	125	17	19.5	1			P433U	-				
ESBN R/L2020W	●	●	20	20	125	17	19.5	2	SN□□1204	B36~	P433W	ESS42	KY40			
ESBN R/L2520			25	20	150	17	24.5	3			P434U	-				
ESBN R/L2520W			25	20	150	17	24.5	2			P434W	ESS42				
ESBN R/L2525			25	25	150	22	24.5	1			P434U	-				
ESBN R/L2525W	●		25	25	150	22	24.5	2			P434W	ESS42				

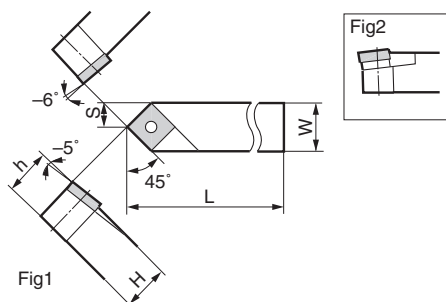
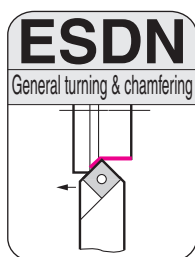

SEC-30 Type Tool Holders

General turning and chamfering
Pin Lock

Parts

Pin	Shim	Wrench				
P321US	-					
P322US	-					
P433U	-					
P433W	ESS42	KY40				
P434U	-					
P434W	ESS42					
P434U	-					
P434W	ESS42					

Holder

Above figures show right hand tools.

Sumitomo Cat. No.	Stock		Dimensions (mm)					Fig	Applicable Insert		Pin	Shim	Wrench			
	R	L	H	W	L	S	h		Cat. No.	Featured page						
ESDN R/L1212	●	●	12	12	80	6	11.5	1	SN□□0903	B35	P321US	-				
ESDN R/L1616H32	●	●	16	16	100	8	15.5	1			P322US	-				
ESDN R/L2020			20	20	125	10	19.5	1			P433U	-				
ESDN R/L2020W	●	●	20	20	125	10	19.5	2	SN□□1204	B36~	P433W	ESS42	KY40			
ESDN R/L2520			25	20	150	10	24.5	1			P434U	-				
ESDN R/L2520W			25	20	150	10	24.5	2			P434W	ESS42				
ESDN R/L2525			25	25	150	12.5	24.5	1			P434U	-				
ESDN R/L2525W	●	●	25	25	150	12.5	24.5	2			P434W	ESS42				

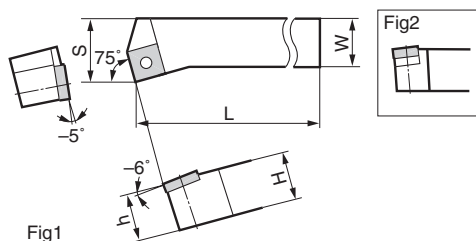

SEC-30 Type Tool Holders

Facing
Pin Lock

Parts

Pin	Shim	Wrench				
P321US	-					
P322US	-					
P432U	-					
P433U	-					
P433W	ESS42	KY40				
P434U	-					
P434W	ESS42					
P434U	-					
P434W	ESS42					

Holder

Above figures show right hand tools.

Sumitomo Cat. No.	Stock		Dimensions (mm)					Fig	Applicable Insert		Pin	Shim	Wrench			
	R	L	H	W	L	S	h		Cat. No.	Featured page						
ESKN R/L1212	●	●	12	12	80	6	11.5	1	SN□□0903	B35	P321US	-				
ESKN R/L1616H32	●	●	16	16	100	20	15.5	1			P322US	-				
ESKN R/L1616H43			16	16	100	20	15.5	1			P432U	-				
ESKN R/L2020			20	20	125	25	19.5	1			P433U	-				
ESKN R/L2020W	●	●	20	20	125	25	19.5	2	SN□□1204	B36~	P433W	ESS42	KY40			
ESKN R/L2520			25	20	150	25	24.5	1			P434U	-				
ESKN R/L2520W			25	20	150	25	24.5	2			P434W	ESS42				
ESKN R/L2525			25	25	150	32	24.5	1			P434U	-				
ESKN R/L2525W	●	●	25	25	150	32	24.5	2			P434W	ESS42				

External Holders

SEC-External Tool Holders ESSN Type

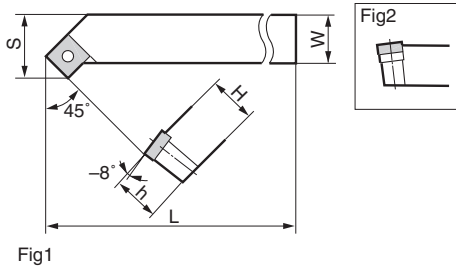
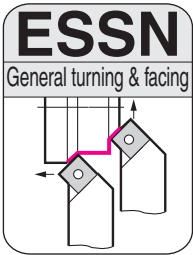

SEC-30 Type Tool Holders

General turning and facing
Pin Lock

Parts

Pin	Shim	Wrench							

Holder

Above figures show right hand tools.

Sumitomo Cat. No.	Stock		Dimensions (mm)					Fig	Applicable Insert		Pin	Shim	Wrench				
	R	L	H	W	L	S	h		Cat. No.	Featured page							
ESSN R/L1212	●	●	12	12	80	16	11.5	1	SN□□0903	B35	P321US	-	KY40				
ESSN R/L1616H32	●	●	16	16	100	20	15.5	1			P322US	-					
ESSN R/L1616H43			16	16	100	20	15.5	1	SN□□1204	B36~	P432U	-					
ESSN R/L2020	●	●	20	20	125	25	19.5	1			P433U	-					
ESSN R/L2020W	●	●	20	20	125	25	19.5	2			P433W	ESS42					
ESSN R/L2520			25	20	150	25	24.5	1			P434U	-					
ESSN R/L2520W			25	20	150	25	24.5	2			P434W	ESS42					
ESSN R/L2525			25	25	150	32	24.5	1			P434U	-					
ESSN R/L2525W	●	●	25	25	150	32	24.5	2			P434W	ESS42					

Insert

PSSN/PSDN/PSBN/PSKN/ESBN/ESDN/ESKN/ESSN Type

Recommended Inserts

- Please also refer to the selection guide for inserts. (B4~)
- Some combinations need to be made-to-order or cannot be manufactured.

Applications	P (Steel)			M (Stainless Steel)			K (Cast Iron)		
	Finishing	Medium Cut	Roughing	Finishing	Medium Cut	Roughing	Finishing	Medium Cut	Roughing
Continuous Cut	SU AC700G	GU AC700G	MU AC2000	SU AC630M	EX AC630M	MU AC630M	SUMIBORON BN700	UZ AC410K	UZ AC410K
General Purpose	SU AC2000	GU AC2000	MU AC2000	SU AC630M	EX AC630M	MU AC630M	SUMIBORON BN700	UX AC410K	UX AC700G
Interrupted Cut	SX AC3000	UX AC3000	MU AC3000	SU AC630M	GU AC3000	MU AC3000	SUMIBORON BN700	UX AC700G	No Breaker AC700G

Applications	H (Hardened Steel)	
	High-speed Finish	Finishing
Continuous Cut	SUMIBORON BNX10	SUMIBORON BN250
General Purpose	SUMIBORON BNC150	SUMIBORON BN250
Interrupted Cut	SUMIBORON BNX25	SUMIBORON BN350

Featured page

	Coated Carbide Coated Cermet Cermet Carbide Ceramics	SUMIBORON SUMIDIA
SN□□0903○○	B35	—
SN□□1204○○	B36~38	B39
SN□□1506○○	B40	—
SN□□1906○○	B41	—
SN□□2507○○	B42	—

SEC-External Tool Holders DTGN/DTFN/PTGN Type

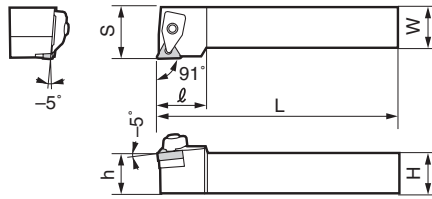
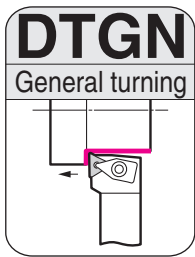

SEC- D Type Holders

General turning
Double Lock

Parts

※Item is sold separately.

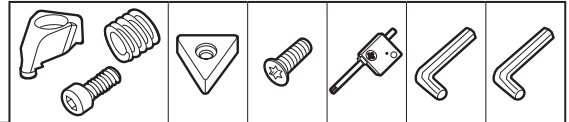

Holder

Above figures show right hand tools.

Sumitomo Cat. No.	Stock		Dimensions (mm)						Applicable Insert		Clamp Set	Shim	Shim Screw	Wrench	Top Wrench	Bottom Wrench
	R	L	H	W	L	S	h	ℓ	Cat. No.	Featured page						
DTGN R/L2020K16	●	●	20	20	125	25	20	31	TN□□1604	B50~	SCP-1	TNS1604	BFTX0307N	TRX10 (※)	LH040	LH025
DTGN R/L2525M16	●	●	25	25	150	32	25	31								

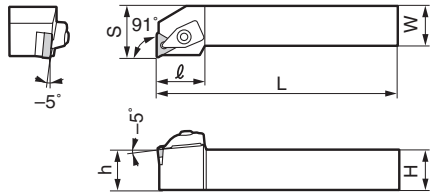
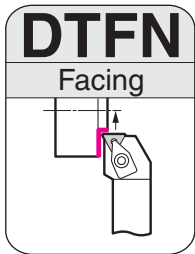

SEC- D Type Holders

Facing
Double Lock

Parts

※Item is sold separately.

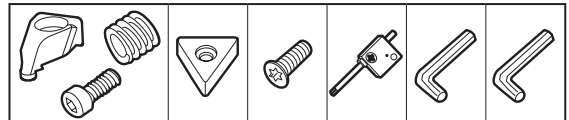

Holder

Above figures show right hand tools.

Sumitomo Cat. No.	Stock		Dimensions (mm)						Applicable Insert		Clamp Set	Shim	Shim Screw	Wrench	Top Wrench	Bottom Wrench
	R	L	H	W	L	S	h	ℓ	Cat. No.	Featured page						
DTFN R/L2020K16	●	●	20	20	125	25	20	30	TN□□1604	B50~	SCP-1	TNS1604	BFTX0307N	TRX10 (※)	LH040	LH025
DTFN R/L2525M16	●	●	25	25	150	32	25	30								

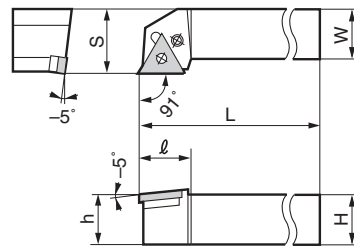
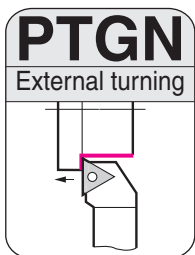

SEC- 70 Type Tool Holders

External turning
Lever Lock

Parts

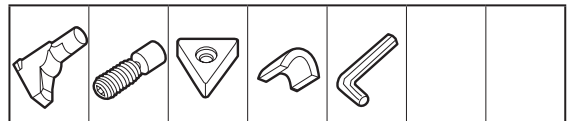

Holder

Above figures show right hand tools.

Sumitomo Cat. No.	Stock		Dimensions (mm)						Applicable Insert		Lever Pin	Clamp Bolt	Shim	Shim Pin	Wrench		
	R	L	H	W	L	S	h	ℓ	Cat. No.	Featured page							
PTGN R/L1616-33	●	●	16	16	100	20	16	20									
PTGN R/L2020-33	●	●	20	20	125	25	20	20									
PTGN R/L2520-33			25	20	150	25	25	20	TN□□1604	B50~	LCL3	LCS3	LST317	LSP3	LH025		
PTGN R/L2525-33	●	●	25	25	150	32	25	20									
PTGN R/L3225-33			32	25	170	32	32	20									
PTGN R/L2525-43	●	●	25	25	150	32	25	28									
PTGN R/L3225-43			32	25	170	32	32	28	TN□□2204	B57~	LCL4	LCS4	LST42	LSP4	LH030		
PTGN R/L3232-43			32	32	170	40	32	28									
PTGN R/L3232-54			32	32	170	40	32	33									
PTGN R/L4040-54			40	40	200	50	40	33	TN□□2706	B59	LCL5	LCS5	LST53	LSP5	LH030		

SEC-External Tool Holders PTTN/PTFN Type

External Holders

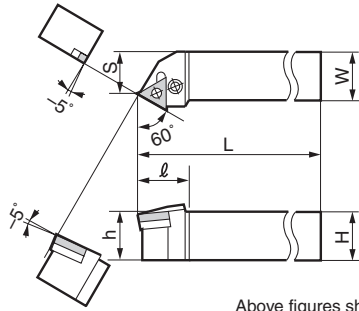
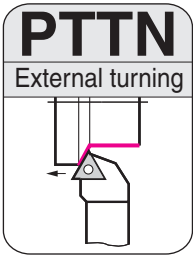

SEC-70 Type Tool Holders

External turning
Lever Lock

Holder

Above figures show right hand tools.

Sumitomo Cat. No.	Stock		Dimensions (mm)						Applicable Insert		Lever Pin	Clamp Bolt	Shim	Shim Pin	Wrench
	R	L	H	W	L	S	h	l	Cat. No.	Featured page					
PTTN R/L1616-33	●	●	16	16	100	13	16	25	TN□□1604	B50~	LCL3	LCS3	LST317	LSP3	LH025
PTTN R/L2020-33	●	●	20	20	125	17	20	25							
PTTN R/L2520-33			25	20	150	17	25	25							
PTTN R/L2525-33	●	●	25	25	150	22	25	25							
PTTN R/L3225-33			32	25	170	22	32	25	TN□□2204	B57~	LCL4	LCS4	LST42	LSP4	LH030
PTTN R/L2525-43			25	25	150	22	25	25							
PTTN R/L3225-43			32	25	170	22	32	25							

Parts

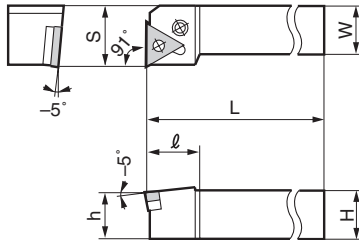
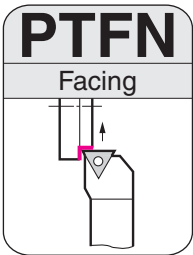
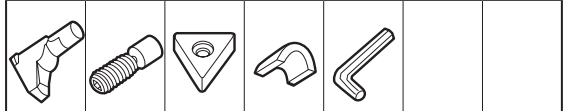

SEC-70 Type Tool Holders

Facing
Lever Lock

Holder

Above figures show right hand tools.

Sumitomo Cat. No.	Stock		Dimensions (mm)						Applicable Insert		Lever Pin	Clamp Bolt	Shim	Shim Pin	Wrench
	R	L	H	W	L	S	h	l	Cat. No.	Featured page					
PTFN R/L1616-33	●	●	16	16	100	20	16	20	TN□□1604	B50~	LCL3	LCS3	LST317	LSP3	LH025
PTFN R/L2020-33	●	●	20	20	125	25	20	20							
PTFN R/L2520-33			25	20	150	25	25	20							
PTFN R/L2525-33	●	●	25	25	150	32	25	20							
PTFN R/L3225-33			32	25	170	32	32	20	TN□□2204	B57~	LCL4	LCS4	LST42	LSP4	LH030
PTFN R/L2525-43	●	●	25	25	150	32	25	25							
PTFN R/L3225-43			32	25	170	32	32	25							
PTFN R/L3232-54			32	32	170	40	32	34	TN□□2706	B59	LCL5	LCS5	LST53	LSP5	LH030
PTFN R/L4040-54			40	40	200	50	40	34							

Parts

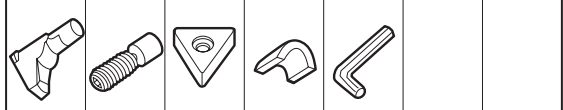

Note: when using right/left handed type inserts, holder and insert are opposite handed.

SEC-External Tool Holders ETGN/ETAN Type

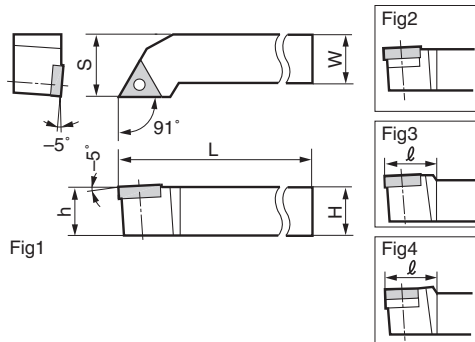
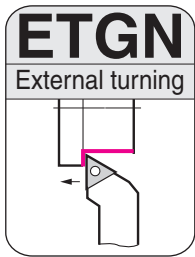

SEC-30 Type Tool Holders

External turning
Pin Lock

Holder

Above figures show right hand tools.

Sumitomo Cat. No.	Stock		Dimensions (mm)						Fig	Applicable Insert		Pin	Shim	Wrench					
	R	L	H	W	L	S	h	ℓ		Cat. No.	Featured page								
ETGN R/L1212	●	●	12	12	80	16	11.5	-	1	TN□□1103	B49	P221US	-	KY25					
ETGN R/L1616-H32	●	●	16	16	100	20	15.5	-	1	TN□□1603	B50	P322US	-	KY40					
ETGN R/L1616-H33	●	●	16	16	100	20	15.5	-	1	TN□□1604	B50~	P332US	-						
ETGN R/L2020-K32			20	20	125	25	19.5	-	1	TN□□1603	B50	P323US	-						
ETGN R/L2020-K32W			20	20	125	25	19.5	-	2			P323WS	EST32						
ETGN R/L2020-K33	●	●	20	20	125	25	19.5	-	1	TN□□1604	B50~	P333US	-						
ETGN R/L2020-K33W	●	●	20	20	125	25	19.5	-	2			P333WS	EST32						
ETGN R/L2520			25	20	150	25	24.5	-	1			P334US	-						
ETGN R/L2520W			25	20	150	25	24.5	-	2			P334WS	EST32						
ETGN R/L2525M33			25	25	150	32	24.5	-	1			P334US	-						
ETGN R/L2525M33W	●	●	25	25	150	32	24.5	-	2			P334WS	EST32						
ETGN R/L2525M43			25	25	150	32	24.5	30	3			TN□□2204	B57~	P434U	-				
ETGN R/L2525M43W	●	●	25	25	150	32	24.5	30	4					P434W	EST43				

Parts

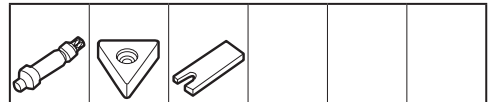

External Holders

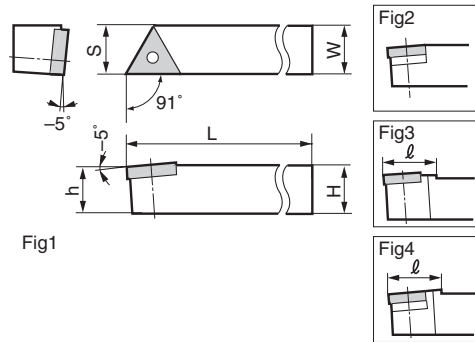
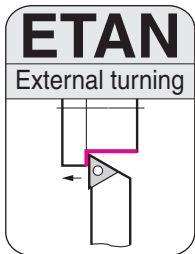

SEC-30 Type Tool Holders

External turning
Pin Lock

Holder

Above figures show right hand tools.

Sumitomo Cat. No.	Stock		Dimensions (mm)						Fig	Applicable Insert		Pin	Shim	Wrench					
	R	L	H	W	L	S	h	ℓ		Cat. No.	Featured page								
ETAN R/L1212	●	●	12	12	80	12	11.5	-	1	TN□□1103	B49	P221US	-	KY25					
ETAN R/L1616H32			16	16	100	16	15.5	-	1	TN□□1603	B50	P322US	-	KY40					
ETAN R/L1616H33	●	●	16	16	100	16	15.5	-	1	TN□□1604	B50~	P332US	-						
ETAN R/L2020K32			20	20	125	20	19.5	-	1	TN□□1603	B50	P323US	-						
ETAN R/L2020K32W			20	20	125	20	19.5	-	2			P323WS	EST32						
ETAN R/L2020K33			20	20	125	20	19.5	-	1	TN□□1604	B50~	P333US	-						
ETAN R/L2020K33W	●	●	20	20	125	20	19.5	-	2			P333WS	EST32						
ETAN R/L2520			25	20	150	20	24.5	-	1			P334US	-						
ETAN R/L2520W			25	20	150	20	24.5	-	2			P334WS	EST32						
ETAN R/L2525M33			25	25	150	25	24.5	-	1			P334US	-						
ETAN R/L2525M33W	●	●	25	25	150	25	24.5	-	2			P334WS	EST32						
ETAN R/L2525M43			25	25	150	25	24.5	30	3			TN□□2204	B57~	P434U	-				
ETAN R/L2525M43W	●	●	25	25	150	25	24.5	30	4					P434W	EST43				

Parts

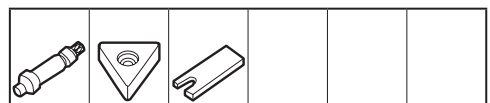

SEC-External Tool Holders ETFN/ETEN Type

External Holders

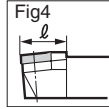
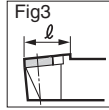
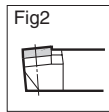
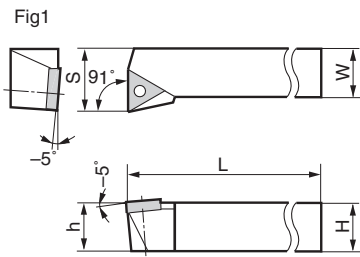
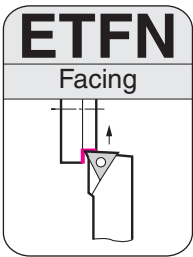

SEC-30 Type Tool Holders

Facing
Pin Lock

Holder

Above figures show right hand tools.

Sumitomo Cat. No.	Stock		Dimensions (mm)							Fig	Applicable Insert		Pin	Shim	Wrench			
	R	L	H	W	L	S	h	ℓ	Cat. No.		Featured page							
ETFN R/L1212	●	●	12	12	80	16	11.5	-	1	TN□□1103	B49	P221US	-	KY25				
ETFN R/L1616H32			16	16	100	20	15.5	-	1	TN□□1603	B50	P322US	-	KY40				
ETFN R/L1616H33	●	●	16	16	100	20	15.5	-	1	TN□□1604	B50~	P332US	-					
ETFN R/L2020K32			20	20	125	25	19.5	-	1	TN□□1603	B50	P323US	-					
ETFN R/L2020K32W			20	20	125	25	19.5	-	2			P323WS	EST32					
ETFN R/L2020K33			20	20	125	25	19.5	-	1			P333US	-					
ETFN R/L2020K33W	●	●	20	20	125	25	19.5	-	2			P333WS	EST32					
ETFN R/L2520			25	20	150	25	24.5	-	1	TN□□1604	B50~	P334US	-					
ETFN R/L2520W			25	20	150	25	24.5	-	2			P334WS	EST32					
ETFN R/L2525M33			25	25	150	32	24.5	-	1			P334US	-					
ETFN R/L2525M33W	●	●	25	25	150	32	24.5	-	2			P334WS	EST32					
ETFN R/L2525M43			25	25	150	32	24.5	30	3	TN□□2204	B57~	P434U	-					
ETFN R/L2525M43W	●	●	25	25	150	32	24.5	30	4			P434W	EST43					

Parts

--	--	--	--	--	--

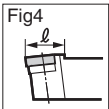
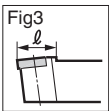
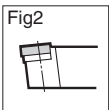
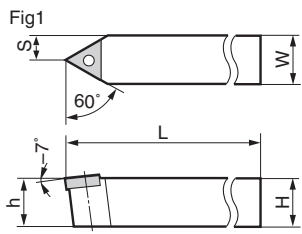
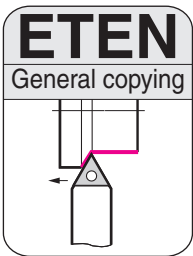

SEC-30 Type Tool Holders

General Copying
Pin Lock

Holder

Sumitomo Cat. No.	Stock	Dimensions (mm)							Fig	Applicable Insert		Pin	Shim	Wrench			
		H	W	L	S	h	ℓ	Cat. No.		Featured page							
ETENN 1212	●	12	12	80	6.0	11.5	-	1	TN□□1103	B49	P221US	-	KY25				
ETENN 1616H32		16	16	100	8.0	15.5	-	1	TN□□1603	B50	P322US	-	KY40				
ETENN 1616H33	●	16	16	100	8.0	15.5	-	1	TN□□1604	B50~	P332US	-					
ETENN 2020K32		20	20	125	10.0	19.5	-	1	TN□□1603	B50	P323US	-					
ETENN 2020K32W		20	20	125	10.0	19.5	-	2			P323WS	EST32					
ETENN 2020K33	●	20	20	125	10.0	19.5	-	1			P333US	-					
ETENN 2020K33W	●	20	20	125	10.0	19.5	-	2			P333WS	EST32					
ETENN 2520		25	20	150	10.0	24.5	-	1	TN□□1604	B50~	P334US	-					
ETENN 2520W		25	20	150	10.0	24.5	-	2			P334WS	EST32					
ETENN 2525M33		25	25	150	12.5	24.5	-	1			P334US	-					
ETENN 2525M33W	●	25	25	150	12.5	24.5	-	2			P334WS	EST32					
ETENN 2525M43		25	25	150	12.5	24.5	30	3	TN□□2204	B51~	P434U	-					
ETENN 2525M43W	●	25	25	150	12.5	24.5	30	4			P434W	EST43					

Parts

--	--	--	--	--	--

SEC-External Tool Holders ETXN/MTJN/MTXN Type

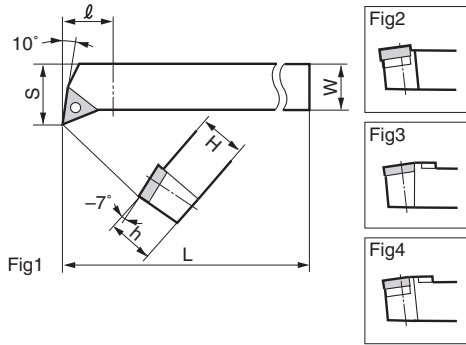
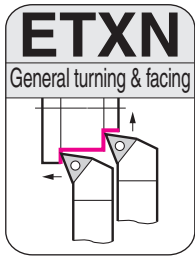

SEC-30 Type Tool Holders General turning and facing
Pin Lock

Parts

Pin	Shim	Wrench					
P221US	-	KY25					
P322US	-						
P332US	-						
P323US	-						
P323WS	EST32						
P333US	-						
P333WS	EST32						
P334US	-						
P334WS	EST32						
P334US	-						
P334WS	EST32						
P434U	-						
P434W	EST43						

Holder

Above figures show right hand tools.

Sumitomo Cat. No.	Stock		Dimensions (mm)						Fig	Applicable Insert		Pin	Shim	Wrench					
	R	L	H	W	L	S	h	l		Cat. No.	Featured page								
ETXN R/L1212	●	●	12	12	80	16	11.5	-	1	TN□□1103	B49	P221US	-	KY25					
ETXN R/L1616H32			16	16	100	20	15.5	-	1	TN□□1603	B50	P322US	-						
ETXN R/L1616H33	●	●	16	16	100	20	15.5	-	1	TN□□1604	B50~	P332US	-						
ETXN R/L2020K32			20	20	125	25	19.5	-	1	TN□□1603	B50	P323US	-						
ETXN R/L2020K32W			20	20	125	25	19.5	-	2			P323WS	EST32						
ETXN R/L2020K33	●	●	20	20	125	25	19.5	-	1	TN□□1604	B50~	P333US	-						
ETXN R/L2020K33W	●	●	20	20	125	25	19.5	-	2			P333WS	EST32						
ETXN R/L2520			25	20	150	25	24.5	-	1			P334US	-						
ETXN R/L2520W			25	20	150	25	24.5	-	2			P334WS	EST32						
ETXN R/L2525M33			25	25	150	32	24.5	-	1	TN□□1604	B50~	P334US	-						
ETXN R/L2525M33W	●	●	25	25	150	32	24.5	-	2			P334WS	EST32						
ETXN R/L2525M43			25	25	150	32	24.5	30	3	TN□□2204	B57~	P434U	-						
ETXN R/L2525M43W	●	●	25	25	150	32	24.5	30	4			P434W	EST43						

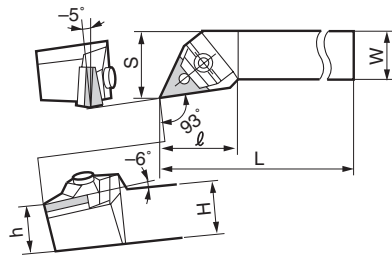
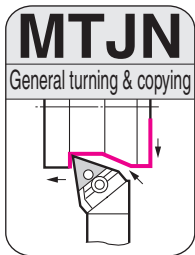

SEC-M Type Copying Holders General turning and copying
Top Clamp

Parts

Clamp	Pin	Shim	Screw	Nut	Ring	Screw Wrench	Nut Wrench
MMW30	MP317S	STW323	BHA0525	CPM32N	ER04	LH030	LH030
MMW40	MP320S	STW434	BHA0625	CPM43N	ER05	LH040	LH030

Holder

Above figures show right hand tools.

Sumitomo Cat. No.	Stock		Dimensions (mm)						Fig	Applicable Insert		Clamp	Pin	Shim	Screw	Nut	Ring	Screw Wrench	Nut Wrench
	R	L	H	W	L	S	h	l		Cat. No.	Featured page								
*MTJN R/L2020-33	●	●	20	20	125	25	20	32		TN□□1604	B50~	MMW30	MP317S	STW323	BHA0525	CPM32N	ER04	LH030	LH030
**MTJN R/L2520-33			25	20	150	25	25	32				MMW30	MP320S	STW323	BHA0525	CPM32N	ER04	LH030	LH030
**MTJN R/L2525-33	●	●	25	25	150	32	25	32		TN□□2204	B57~	MMW40	MP320S	STW434	BHA0625	CPM43N	ER05	LH040	LH030
MTJN R/L2525-43	●	●	25	25	150	32	25	38				MMW40	MP420	STW434	BHA0625	CPM43N	ER05	LH040	LH030
MTJN R/L3225-43	●	●	32	25	170	32	32	38				MMW40	MP420	STW434	BHA0625	CPM43N	ER05	LH040	LH030

When using CIS standard inserts, Pin for holders marked * is MP317 and for holders marked ** is MP320

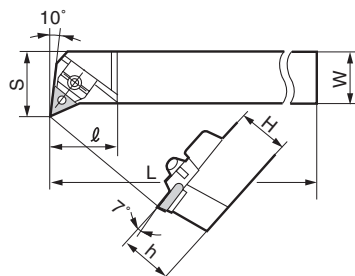
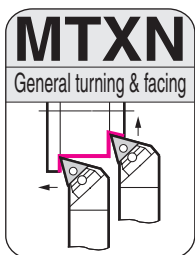

SEC-M Type Copying Holders General turning and facing
Top Clamp

Parts

Clamp	Pin	Shim	Screw	Nut	Ring	Screw Wrench	Nut Wrench
MMW30	MP317S	STW323	BHA0525	CPM32N	ER04	LH030	LH030
MMW40	MP320S	STW434	BHA0625	CPM43N	ER05	LH040	LH030

Holder

Above figures show right hand tools.

Sumitomo Cat. No.	Stock		Dimensions (mm)						Fig	Applicable Insert		Clamp	Pin	Shim	Screw	Nut	Ring	Screw Wrench	Nut Wrench
	R	L	H	W	L	S	h	l		Cat. No.	Featured page								
*MTXN R/L2020-33	●	●	20	20	125	25	20	32		TN□□1604	B50~	MMW30	MP317S	STW323	BHA0525	CPM32N	ER04	LH030	LH030
**MTXN R/L2525-33	●	●	25	25	150	32	25	32				MMW30	MP320S	STW323	BHA0525	CPM32N	ER04	LH030	LH030
MTXN R/L2525-43	●	●	25	25	150	32	25	38		TN□□2204	B57~	MMW40	MP420	STW434	BHA0625	CPM43N	ER05	LH040	LH030

When using CIS standard inserts, Pin for holders marked * is MP317 and for holders marked ** is MP320

SEC-External Tool Holders Insert



























External Holders









Insert

DTGN/DTFN/PTGN/PTTN/PTFN/ETGN/ETAN/ETFN/ETEN/ETXN/MTJN/MTXN Type

Recommended Inserts

- Please also refer to the selection guide for inserts. (B4~)
- Some combinations need to be made-to-order or cannot be manufactured.

Applications Conditions	P (Steel)			M (Stainless Steel)			K (Cast Iron)		
	Finishing	Medium Cut	Roughing	Finishing	Medium Cut	Roughing	Finishing	Medium Cut	Roughing
Continuous Cut	SU  AC700G	GU  AC700G	MU  AC700G	SU  AC630M	EX  AC630M	MU  AC630M	SUMIBORON  BN700	UZ  AC410K	UZ  AC410K
General Purpose	SU  AC2000	GU  AC2000	MU  AC2000	SU  AC630M	EX  AC630M	MU  AC630M	SUMIBORON  BN700	UX  AC410K	UX  AC700G
Interrupted Cut	SX  AC3000	UX  AC3000	MU  AC3000	SU  AC630M	GU  AC3000	MU  AC3000	SUMIBORON  BN700	UX  AC700G	No Breaker  AC700G

Applications Conditions	N (Non-ferrous)	H (Hardened Steel)	
	—	High-speed Finish	Finishing
Continuous Cut	SUMIDIA  DA2200	SUMIBORON  BNC100, BNX10	SUMIBORON  BNC200, BN250
General Purpose	SUMIDIA  DA2200	SUMIBORON  BNC100, BNX20	SUMIBORON  BNC200, BN250
Interrupted Cut	SUMIDIA  DA2200	SUMIBORON  BNX25	SUMIBORON  BNC300, BN350

Featured page

	Coated Carbide Coated Cermet Cermet Carbide Ceramics	SUMIBORON SUMIDIA
TN□□1103○○	B49	—
TN□□1603○○	B50	—
TN□□1604○○	B50~54	B55~56
TN□□2204○○	B57~58	B59
TN□□2706○○	B59	—

SEC-External Tool Holders DVJN/DVVN/DVQN Type

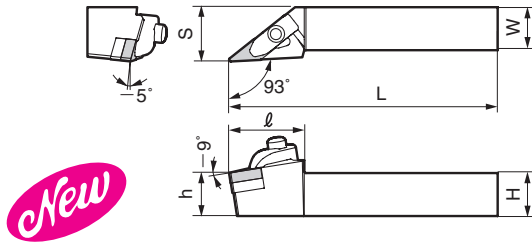
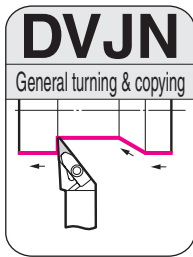

New

SEC- D Type Holders

General turning and copying
Double Lock

Holder

Above figures show right hand tools.

Sumitomo Cat. No.	Stock		Dimensions (mm)						Applicable Insert	
	R	L	H	W	L	S	h	ℓ	Cat. No.	Featured page
DVJN R/L2020K16	●	●	20	20	125	25	20	35	VN□□1604	B63~
DVJN R/L2525M16	●	●	25	25	150	32	25	35		

Parts

※Item is sold separately.

Clamp Set	Shim	Shim Screw	Wrench	Top Wrench	Bottom Wrench
SCP-4	VNS1604	BFTX0307N	TRX10 (※)	LH040	LH025

External Holders

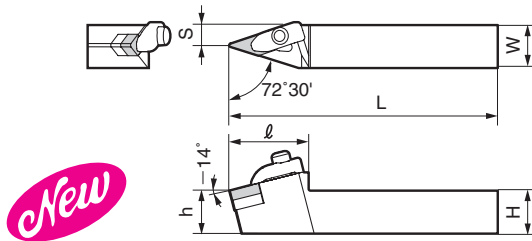
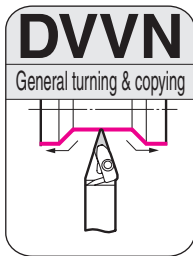

New

SEC- D Type Holders

General turning and copying
Double Lock

Holder

Sumitomo Cat. No.	Stock		Dimensions (mm)						Applicable Insert	
	R	L	H	W	L	S	h	ℓ	Cat. No.	Featured page
DVVN N2020K16	●	●	20	20	125	10	20	37	VN□□1604	B63~
DVVN N2525M16	●	●	25	25	150	12.5	25	37		

Parts

※Item is sold separately.

Clamp Set	Shim	Shim Screw	Wrench	Top Wrench	Bottom Wrench
SCP-4	VNS1604	BFTX0307N	TRX10 (※)	LH040	LH025

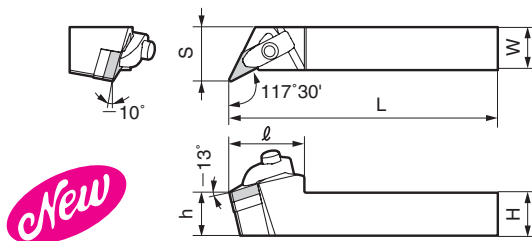

New

SEC- D type Holder

General turning / Copying / Necking
Double Lock

Holder

Above figures show right hand tools.

Sumitomo Cat. No.	Stock		Dimensions (mm)						Applicable Insert	
	R	L	H	W	L	S	h	ℓ	Cat. No.	Featured page
DVQN R/L2020K16	●	●	20	20	125	25	20	35	VN□□1604	B63~
DVQN R/L2525M16	●	●	25	25	150	32	25	35		

Parts

※Item is sold separately.

Clamp Set	Shim	Shim Screw	Wrench	Top Wrench	Bottom Wrench
SCP-4	VNS1604	BFTX0307N	TRX10 (※)	LH040	LH025

SEC-External Tool Holders CVC/CVJ Type

External Holders

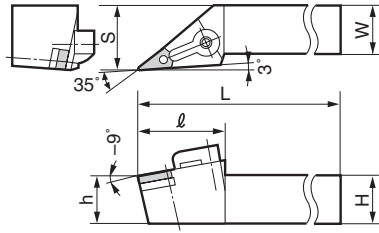
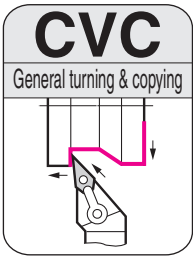

SEC-60 Type Tool Holders

General turning and copying

Top Clamp + Pin Lock

Holder

Above figures show right hand tools.

Sumitomo Cat. No.	Stock		Dimensions (mm)						Applicable Insert		Pin	Clamp	Double Screw	Shim	Wrench	Wrench	
	R	L	H	W	L	S	h	ℓ	Cat. No.	Featured page							
CVC R/L33-3S	▲	▲	20	20	125	25	20	42	VN□□1604	B63~	CPZ333V	CCM8-LONG	WB8-30	SVW322	LH040	KY25	
CVC R/L44-3S	▲	▲	25	25	150	32	25	42			CPZ334V						

Parts

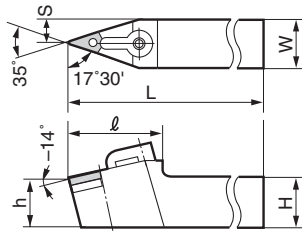
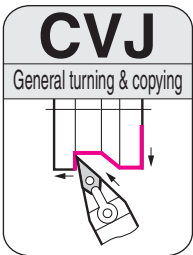
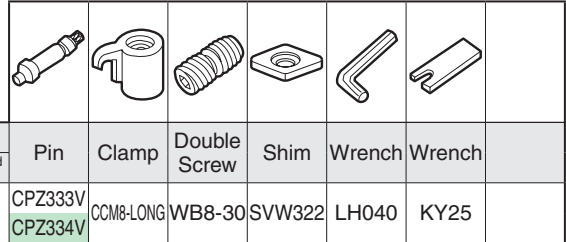

SEC-60 Type Tool Holders

General turning and copying

Top Clamp + Pin Lock

Holder

Sumitomo Cat. No.	Stock		Dimensions (mm)						Applicable Insert		Pin	Clamp	Double Screw	Shim	Wrench	Wrench	
	H	W	L	S	h	ℓ	Cat. No.	Featured page									
CVJM 33-3S	▲	▲	20	20	125	10	20	45	VN□□1604	B63~	CPZ333V	CCM8-LONG	WB8-30	SVW322	LH040	KY25	
CVJM 44-3S	▲	▲	25	25	150	12.5	25	45			CPZ334V						

Parts



Insert DVJN/DVQN/DVVN/CVC/CVJ Type

Recommended Inserts

- Please also refer to the selection guide for inserts. (B4)
- Some combinations need to be made-to-order or cannot be manufactured.

Applications Conditions	P (Steel)		M (Stainless Steel)		K (Cast Iron)		
	Finishing	Medium Cut	Finishing	Medium Cut	Finishing	Medium Cut	Roughing
Continuous Cut	SU AC700G	GU AC700G	SU AC630M	EX AC630M	SUMIBORON BN700	UZ AC410K	UZ AC410K
General Purpose	SU AC2000	GU AC2000	SU AC630M	EX AC630M	SUMIBORON BN700	UX AC410K	UX AC700G
Interrupted Cut	SX AC3000	UX AC3000	SU AC630M	GU AC3000	SUMIBORON BN700	UX AC700G	No Breaker AC700G

Applications Conditions	N (Non-ferrous)	H (Hardened Steel)	
	—	High-speed Finish	Finishing
Continuous Cut	SUMIDIA DA2200	SUMIBORON BNC100, BNX10	SUMIBORON BNC200, BN250
General Purpose	SUMIDIA DA2200	SUMIBORON BNC100, BNX20	SUMIBORON BNC200, BN250
Interrupted Cut	SUMIDIA DA2200	SUMIBORON BNX25	SUMIBORON BNC300, BN350

Featured page

	Coated Carbide Coated Cermet Cermet Carbide Ceramics	SUMIBORON SUMIDIA
	B63~64	B65~66

SEC-External Tool Holders DWLN/PWLN/MWLN Type

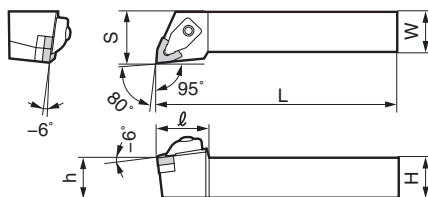
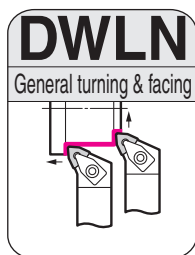

SEC-D Type Holders

General turning and facing
Double Lock

Parts

※Item is sold separately.

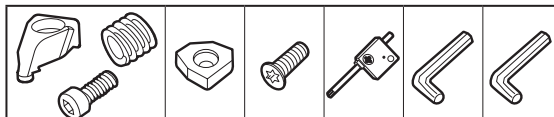

Holder

Above figures show right hand tools.

Sumitomo Cat. No.	Stock		Dimensions (mm)						Applicable Insert		Clamp Set	Shim	Shim Screw	Wrench	Top Wrench	Bottom Wrench
	R	L	H	W	L	S	h	l	Cat. No.	Featured page						
DWLN R/L2020K08	●	●	20	20	125	25	20	32	WN□□0804	B68~	SCP-2	WNS0804	BFTX0409N	TRX15 (※)	LH040	LH025
DWLN R/L2525M08	●	●	25	25	150	32	25	32								

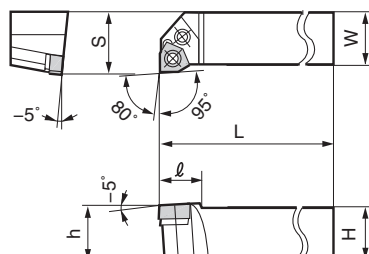
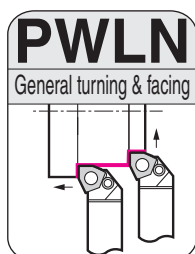

SEC-70 Type Tool Holders

General turning and facing
Lever Lock

Parts

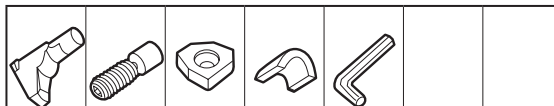

Holder

Above figures show right hand tools.

Sumitomo Cat. No.	Stock		Dimensions (mm)						Applicable Insert		Lever Pin	Clamp Bolt	Shim	Shim Pin	Wrench		
	R	L	H	W	L	S	h	l	Cat. No.	Featured page							
PWLN R/L2020-33	●	●	20	20	125	25	20	17	WN□□0604	B67	LCL3	LCS3	LSW317	LSP3	LH025		
PWLN R/L2525-33	●	●	25	25	150	32	25	17									

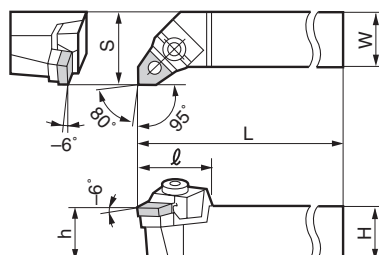
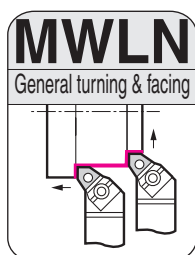

SEC-M Type Copying Holders

General turning and facing
Top Clamp + Pin Lock

Parts

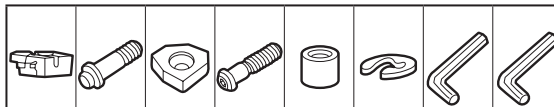

Holder

Above figures show right hand tools.

Sumitomo Cat. No.	Stock		Dimensions (mm)						Applicable Insert		Clamp	Pin	Shim	Screw	Nut	Ring	Screw Wrench	Nut Wrench
	R	L	H	W	L	S	h	l	Cat. No.	Featured page								
MWLN R/L2020-43	●	●	20	20	125	25	20	32			MWW40	MP416			CPM43S			
MWLN R/L2525-43	●	●	25	25	150	32	25	32	WN□□0804	B68~		MP420	SWW433	BHA0625	CPM43N	ER05	LH040	LH030
MWLN R/L3225-43	●	●	32	25	170	32	32	32				MP420			CPM43N			

SEC-External Tool Holders Insert



























External Holders







Insert

DWLN/PWLN/MWLN Type

Recommended Inserts

- Please also refer to the selection guide for inserts. (B4~)
- Some combinations need to be made-to-order or cannot be manufactured.

Applications Conditions	P (Steel)			M (Stainless Steel)			K (Cast Iron)		
	Finishing	Medium Cut	Roughing	Finishing	Medium Cut	Roughing	Finishing	Medium Cut	Roughing
Continuous Cut	SU  AC700G	GU  AC700G	MU  AC700G	SU  AC630M	EX  AC630M	MU  AC630M	SUMIBORON  BN700	UZ  AC410K	UZ  AC410K
General Purpose	SU  AC2000	GU  AC2000	MU  AC2000	SU  AC630M	EX  AC630M	MU  AC630M	SUMIBORON  BN700	UX  AC410K	UX  AC700G
Interrupted Cut	SX  AC3000	UX  AC3000	MU  AC3000	SU  AC630M	GU  AC3000	MU  AC3000	SUMIBORON  BN700	UX  AC700G	No Breaker  AC700G

Applications Conditions	H (Hardened Steel)	
	High-speed Finish	Finishing
Continuous Cut	SUMIBORON  BNC100	SUMIBORON  BNC200, BN250
General Purpose	SUMIBORON  BNC100	SUMIBORON  BNC200, BN250
Interrupted Cut	SUMIBORON  BNX25	SUMIBORON  BN350

Featured page

	Coated Carbide Coated Cermet Cermet Carbide Ceramics	SUMIBORON SUMIDIA
WN□□0604○○	B67	—
WN□□0804○○	B68~69	B70

SEC-External Tool Holders PRGC/PRDCN Type

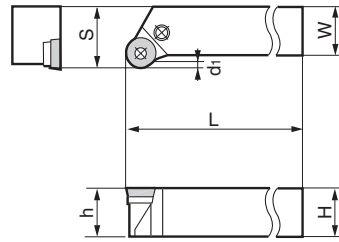
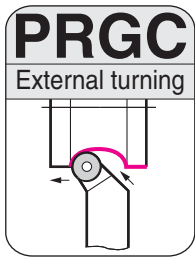

SEC-70 Type Tool Holders

External turning
Lever Lock

Holder

Above figures show right hand tools.

Sumitomo Cat. No.	Stock		Dimensions (mm)							Applicable Insert		Lever Pin	Clamp Bolt	Shim	Shim Pin	Wrench		
	R	L	H	W	L	S	h	d1	Cat. No.	Featured page								
PRGC R/L2020K10	●	●	20	20	125	25	20	1.5	RCM□1003M0	B96	LCL10	LCS10	LSR10	LSP10	LH020			
PRGC R/L2525M10	●	●	25	25	150	32	25	1.5										
PRGC R/L2020K12	●	●	20	20	125	25	20	2.5	RCM□1204M0	B96	LCL12	LCS12	LSR12	LSP10	LH025			
PRGC R/L2525M12	●	●	25	25	150	32	25	2.5										
PRGC R/L3225P12	●	●	32	25	170	32	32	2.5	RCM□1606M0	B96	LCL16	LCS16	LSR16	LSP16	LH025			
PRGC R/L2525M16			25	25	150	32	25	3.0										
PRGC R/L3225P16			32	25	170	32	32	3.0	RCM□2006M0	B96	LCS20	LCS20	LSR20	LSP20	LH030			
PRGC R/L3232P20			32	32	170	40	32	4.0										
PRGC R/L4040S25			40	40	250	50	40	4.5	RCM□2507M0	B96	LCL25	LCS25	LSR25	LSP25	LH040			
PRGC R/L5050T32			50	50	300	63	50	5.5	RCM□3209M0	B96	LCL32	LCS32	LSR32	LSP32	LH050			

Parts

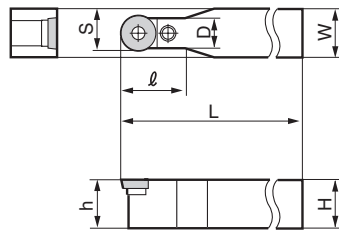
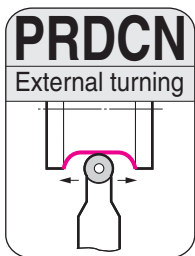

SEC-70 Type Tool Holders

External turning
Lever Lock

Holder

Sumitomo Cat. No.	Stock	Dimensions (mm)							Applicable Insert		Lever Pin	Clamp Bolt	Shim	Shim Pin	Wrench		
		H	W	L	S	h	ℓ	D	Cat. No.	Featured page							
PRDCN 2020M10	●	20	20	150	15	20	22	8.0	RCM□1003M0	B96	LCL10	LCS10	LSR10	LSP10	LH020		
PRDCN 2525M12	●	25	25	150	18.5	25	24	9.6									
PRDCN 3225Q12	●	32	25	180	18.5	32	24	9.6	RCM□1204M0	B96	LCL12	LCS12	LSR12	LSP10	LH025		
PRDCN 3225Q16	●	32	25	180	20.5	32	28	13.0									
PRDCN 3232Q20	●	32	32	180	26	32	32	16.6	RCM□2006M0	B96	LCL20	LCS20	LSR20	LSP20	LH030		
PRDCN 4040T25		40	40	300	32.5	40	42	21.0	RCM□2507M0	B96	LCL25	LCS25	LSR25	LSP25	LH040		
PRDCN 5050U32		50	50	350	41	50	52	27.0	RCM□3209M0	B96	LCL32	LCS32	LSR32	LSP32	LH050		

Parts



SEC-External Tool Holders SVJC/SVVC/SVPC Type

External Holders

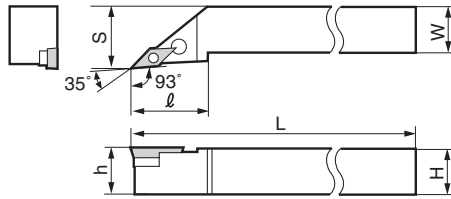
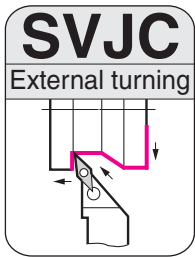

SEC- SV Type Copying Tool Holders

External turning
Screw Lock

Holder

Above figures show right hand tools.

Sumitomo Cat. No.	Stock		Dimensions (mm)						Applicable Insert		Pin	Nut	Shim	Screw	Wrench	Wrench	
	R	L	H	W	L	S	h	ℓ	Cat. No.	Featured page							
SVJC R/L2020-33	●	●	20	20	125	25	20	41			VP20						
SVJC R/L2525-33	●	●	25	25	150	32	25	41	VC□□1604	B143~	VP25	CPV33N	SVP32	BFTX03508	TRX10	LH025	
SVJC R/L3225-33	●	●	32	25	170	32	32	41			VP32						

Parts

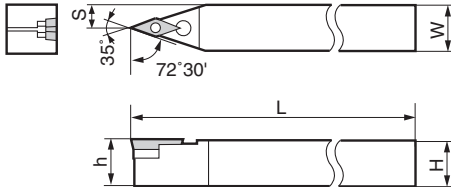
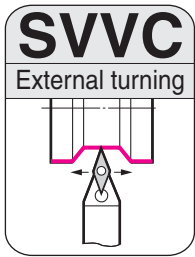
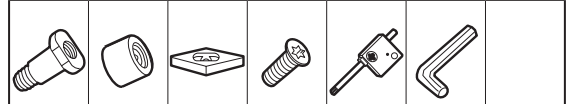

SEC- SV Type Copying Tool Holders

External turning
Screw Lock

Holder

Sumitomo Cat. No.	Stock		Dimensions (mm)						Applicable Insert		Pin	Nut	Shim	Screw	Wrench	Wrench
	R	L	H	W	L	S	h	ℓ	u	Cat. No.						
SVVCN2020-33	●	●	20	20	125	10.0	20				VP20					
SVVCN2525-33	●	●	25	25	150	12.5	25		VC□□1604	B143~	VP25	CPV33N	SVP32	BFTX03508	TRX10	LH025
SVVCN3225-33	●	●	32	25	170	12.5	32				VP32					

Parts

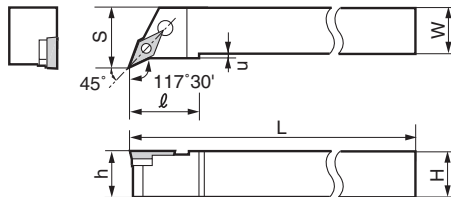
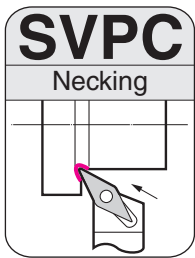

SEC- SV Type Copying Tool Holders

Necking
Screw Lock

Holder

Above figures show right hand tools.

Sumitomo Cat. No.	Stock		Dimensions (mm)						Applicable Insert		Pin	Nut	Shim	Screw	Wrench	Wrench	
	R	L	H	W	L	S	h	ℓ	u	Cat. No.							Featured page
SVPC R/L2020-33	●	●	20	20	125	25	20	35	1.6			VP20					
SVPC R/L2525-33	●	●	25	25	150	32	25	35	3.6	VC□□1604	B143~	VP25	CPV33N	SVP32	BFTX03508	TRX10	LH025
SVPC R/L3225-33	●	●	32	25	170	32	32	35	3.6			VP32					

Parts



SEC-External Tool Holders FP11/FP14/FP15 Type

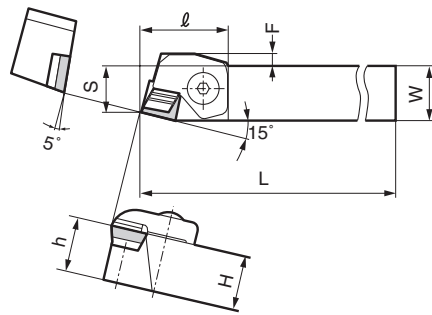
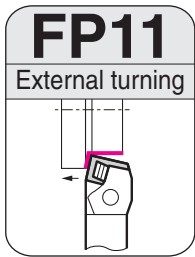

SEC-40 Type Tool Holders

External turning

Top Clamp

Holder

Above figures show right hand tools.

Sumitomo Cat. No.	Stock		Dimensions (mm)								Applicable Insert	
	R	L	H	W	L	S	h	ℓ	D	F	Cat. No.	Featured page
FP11 R/L-33	●		19	19	140	15.5	19	34.5	-	5		
FP11 R/L-44A	●		25	25	160	21.5	25	34.5	-	-	SP□□1203	B107~
FP11 R/L-45A			32	25	160	21.5	32	34.5	-	-		
FP11 R/L-44B	●		25	25	160	21.5	25	40	-	4.5	SP□□1504	B109
FP11 R/L-55			32	32	180	26	32	40	-	-		

Parts

Pin	Chipbreaker	Clamp Bolt	Shim	Shim Pin	Spring	Wrench
		BH0824R/L				
DCR/L1	CBD4R/L	BH0830R/L	SSPD422			LH040
		BH0830R/L		SPP3	DSP5	
		BH1030R/L	SSPD522			LH050
		BH1036R/L				

External Holders

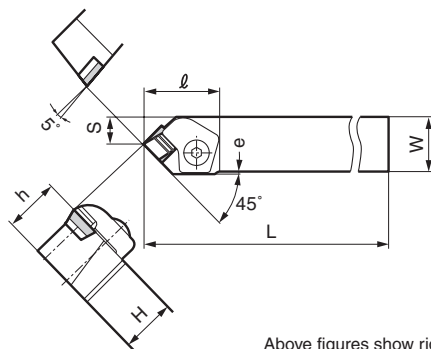
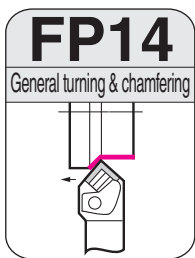

SEC-40 Type Tool Holders

General turning and chamfering

Top Clamp

Holder

Above figures show right hand tools.

Sumitomo Cat. No.	Stock		Dimensions (mm)								Applicable Insert	
	R	L	H	W	L	S	h	ℓ	e	F	Cat. No.	Featured page
FP14 R/L-33	●		19	19	140	10.5	19	35	6	-		
FP14 R/L-44A	●		25	25	160	12.5	25	35	2	-	SP□□1203	B107~
FP14 R/L-45A			32	25	160	12.5	32	35	2	-		

Parts

Pin	Chipbreaker	Clamp Bolt	Shim	Shim Pin	Spring	Wrench
		BH0824R/L				
DCR/L1	CBD4R/L	BH0830R/L	SSPD422	SPP3	DSP5	LH040
		BH0830R/L				

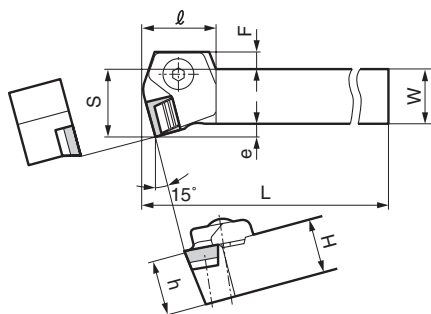
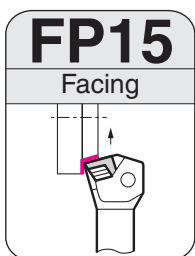

SEC-40 Type Tool Holders

Facing

Top Clamp

Holder

Above figures show right hand tools.

Sumitomo Cat. No.	Stock		Dimensions (mm)								Applicable Insert	
	R	L	H	W	L	S	h	ℓ	e	F	Cat. No.	Featured page
FP15 R/L-33			19	19	140	25	19	22	6	7		
FP15 R/L-44A	●		25	25	160	32	25	22	7	-	SP□□1203	B107~
FP15 R/L-45A			32	25	160	32	32	22	7	-		
FP15 R/L-44B	●		25	25	160	31	25	28	6	7	SP□□1504	B109
FP15 R/L-55			32	32	180	38	32	28	6	-		

Parts

Pin	Chipbreaker	Clamp Bolt	Shim	Shim Pin	Spring	Wrench
		BH0824R/L				
DCR/L1	CBD4R/L	BH0830R/L	SSPD422			LH040
		BH0830R/L		SPP3	DSP5	
		BH1030R/L	SSPD522			LH050
		BH1036R/L				

Note: when using right/left handed type inserts, holder and insert are opposite handed.

SEC-External Tool Holders FP21/FP22/FP25 Type

External Holders

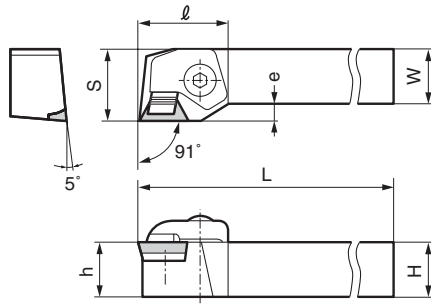

SEC-40 Type Tool Holders

External turning
Top Clamp

Holder

Above figures show right hand tools.

Sumitomo Cat. No.	Stock		Dimensions (mm)							Applicable Insert		Pin	Chipbreaker	Clamp Bolt	Shim	Shim Pin	Spring	Wrench
	R	L	H	W	L	S	h	ℓ	e	Cat. No.	Featured page							
FP21 R/L-44A	●		25	25	160	25	25	34.5	-	TP□□1603	B133~	DCR/L2	CBD4R/L	BH0830R/L	STPD322			LH040
FP21 R/L-45A			32	25	160	25	32	34.5	-			DCR/L2	CBD4R/L	BH0830R/L	STPD322			LH040
FP21 R/L-55			32	32	180	32	32	41	-	TP□□2204	B135	DCR/L3	CBD5R/L	BH1036R/L	STPD422	SPP3	DSP5	LH050
FP22 R/L-33	●		19	19	140	25	19	34.5	6	TP□□1603	B133~	DCR/L2	CBD4R/L	BH0824R/L	STPD322			LH040
FP22 R/L-44B	●		25	25	160	32	25	41	7	TP□□2204	B135	DCR/L3	CBD5R/L	BH1030R/L	STPD422			LH050

Parts

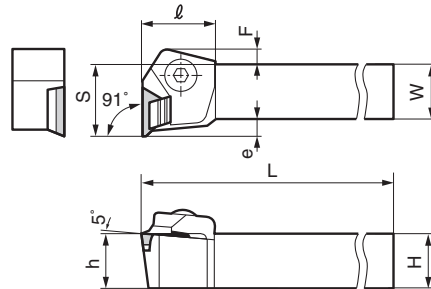
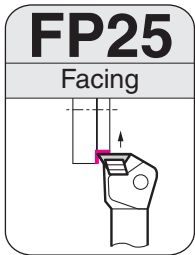

SEC-40 Type Tool Holders

Facing
Top Clamp

Holder

Above figures show right hand tools.

Sumitomo Cat. No.	Stock		Dimensions (mm)								Applicable Insert		Pin	Chipbreaker	Clamp Bolt	Shim	Shim Pin	Spring	Wrench
	R	L	H	W	L	S	h	ℓ	e	F	Cat. No.	Featured page							
FP25 R/L-33	●		19	19	140	25	19	26	6	8					BH0824R/L				
FP25 R/L-44A	●		25	25	160	32	25	26	7	-	TP□□1603	B133~	DCL/R2	CBD4L/R	BH0830R/L	STPD322			LH040
FP25 R/L-45A			32	25	160	32	32	26	7	-					BH0830R/L		SPP3	DSP5	
FP25 R/L-44B	●		25	25	160	32	25	33	7	7	TP□□2204	B135	DCL/R3	CBD5L/R	BH1030R/L	STPD422			LH040
FP25 R/L-55			32	32	180	39	32	33	7	-					BH1036R/L				

Parts

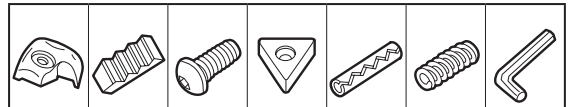

Note: when using right/left handed type inserts, holder and insert are opposite handed.

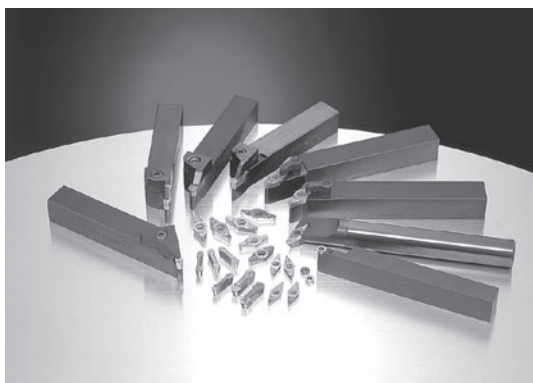





■ Features

With a wide range of insert geometries (35° diamond shaped type, Dog bone type and Round type) available in both cemented carbide and diamond grades, we are able to provide superior performance for a vast variety of applications and cutting conditions.

■ Characteristics

- With our new range of tool holders for 35° diamond shaped inserts, with AW type chipbreakers, we are able to expand our applications to cover roughing to finishing processes.
- Our Dog bone inserts, available in both cemented carbide and diamond grades (with or without chipbreaker), are used with our range of special holders for a wide variety of application processes.
- A combination of Round insert with WF style, in DA2200 grade is used to obtain high quality finishing.

■ Insert

- 35° diamond type
 VCGT220520N-AW (H1)
- Dog bone type
 MDE4R-AW(H1)
- Dog bone type
 MDE4R-AW (DA2200)
- AG Chipbreaker
 - 35° diamond type
 VCGT160408N-AG (H1)

■ Series

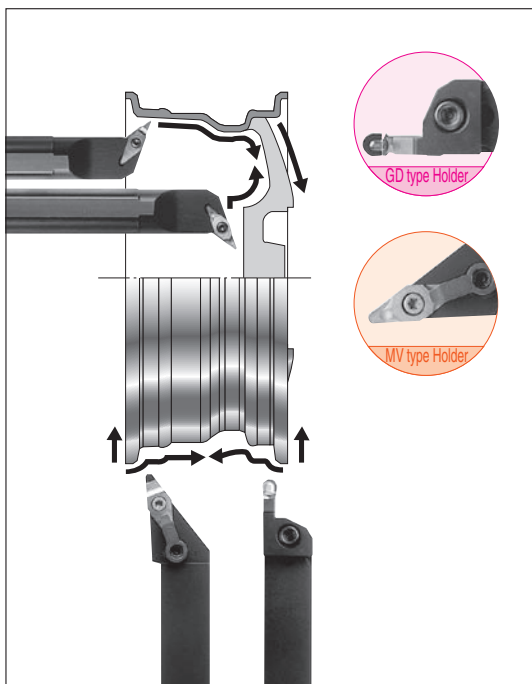

Holder	Cat No.	Page
SEC-GD Type	GDE R/L2525-600W,S	C33
	GDE R/L2525-800W,S	
	GDE R/L2525-615W,S	
	GDE R/L2525-815W,S	
	GDE R/L2525-645W,S	
	GDE R/L2525-845W,S	
SEC-SV Type	SVJC R/L2525-33	C28
	SVVCN2525-33	
	SVPC R/L2525-33	
SEC-MV Type	MVXC R/L2525-2220	C32
	MVXC R/L2525-2230	
	MVPC R/L2525-2220	
	MVPC R/L2525-2230	
SEC-D Type	DVJN R/L2525 M16	C23
	DVNN 2525 M16	
	DVQN R/L2525 M16	
SEC-Boring Bar	S25R-SVQC R/L16	D36
	S32S-SVQC R/L16	
	S40V-SVQC R/L16	
	S25R-SVUC R/L16	
	S32S-SVUC R/L16	
	S40V-SVUC R/L16	

■ Application Examples

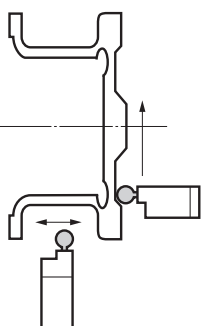

● **Conditions**
 Holder : GDER2525-800W
 Insert : MDE4R-AW
 Grade : H1
 N=2000min⁻¹
 f=0.4~0.6mm/rev.
 d=2.0mm, Wet

● **Result**
 Excellent chip control of AW breaker guarantees an increase in productivity.

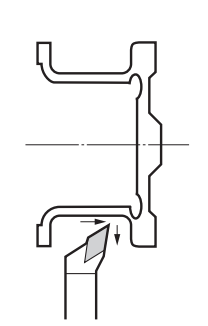

● **Conditions**
 Holder : SVJCR2525-33
 Insert : VCMT160412
 Grade : DA2200
 V=2500m/min.
 f=0.35mm/rev.
 d=0.2mm, Wet

● **Result**
 DA2200 has excellent toughness, and provides over 16 times tool life when compared to competitor's PCD.

DA2200 3,500pcs.
 Competition's 200pcs.

Toll life

SEC-Copying Tool Holders MV Type

35° Diamond insert type

External Holders

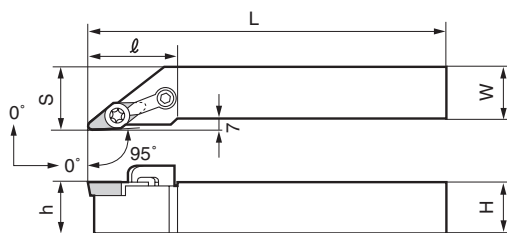
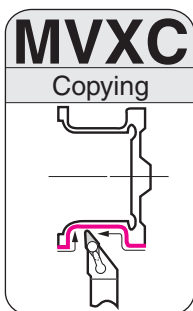

Holder

Above figures show right hand tools.

Sumitomo Cat. No.	Stock		Dimensions (mm)						Clamp	Double Screw	Screw	Wrench	Wrench
	R	L	H	W	L	S	h	ℓ					
★ MVXC R/L2525-2220	●	●	25	25	180	32	25	45	CCM8-LONG	WB8-24	BFTX0515N	TRX20	LH040
☆ MVXC R/L2525-2230	●	●	25	25	180	32	25	45					

Parts

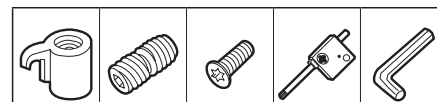

★: For nose radius 2.0 insert. ☆: For nose radius 3.0 insert.

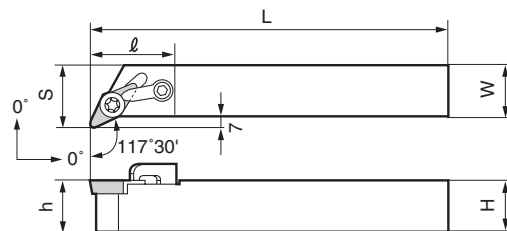
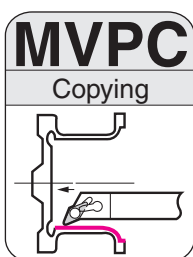

Holder

Above figures show right hand tools.

Sumitomo Cat. No.	Stock		Dimensions (mm)						Clamp	Double Screw	Screw	Wrench	Wrench
	R	L	H	W	L	S	h	ℓ					
★ MVPC R/L2525-2220	●	●	25	25	180	32	25	41	CCM8-LONG	WB8-24	BFTX0515N	TRX20	LH040
☆ MVPC R/L2525-2230	●	●	25	25	180	32	25	41					

Parts

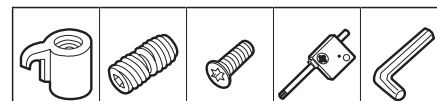

★: For nose radius 2.0 insert. ☆: For nose radius 3.0 insert.

Insert

(Coated / Carbide / SUMIDIA)

● 35° Diamond type

Shape	ISO Cat. No.	Stock				Dimensions (mm)			Applicable Toolholder
		EH10Z	G10E	H1	DA2200	Inscribed circle	Thickness	Nose radius	
	VCGT220520N-AW	-	-	●	-	12.70	5.56	2.0	MVXC Type MVPC Type
	VCGT220530N-AW	-	-	●	-			3.0	
	VCGT220530N-AG	-	-	●	-	12.70	5.56	3.0	
	VCGT220530N-AG	-	-	●	-	12.70	5.56	3.0	
	VCMT220520	-	-	-	●	12.70	5.56	2.0	SVJC Type (→ C28) SVVC Type (→ C28) SVPC Type (→ C28)
	VCMT220530	-	-	-	●			3.0	
	VCGT160408N-AW	-	-	●	-	9.525	4.76	0.8	
	VCGT160412N-AW	-	-	●	-			1.2	
	VCGT160408N-AG	-	-	●	-	9.525	4.76	0.8	
	VCGT160412N-AG	-	-	●	-	9.525	4.76	1.2	
	NF-VCMT160404	-	-	-	●	9.525	4.76	0.4	
	NF-VCMT160408	-	-	-	●			0.8	
	NF-VCMT160412	-	-	-	●			1.2	
	VCMT160408	-	-	-	●	9.525	4.76	0.8	
	VCMT160412	-	-	-	●			1.2	
	VCMT160412-WF	-	-	-	●	9.525	4.76	1.2	
	VCMT160412-WF	-	-	-	●			1.2	
	VNMG160404N-UP	-	●	-	-	9.525	4.76	0.4	DVVN Type (→ C23) DVJN Type (→ C23) DVQN Type (→ C23)
	VNMG160408N-UP	-	●	-	-			0.8	
	NF-VNMX160404	-	-	-	●	9.525	4.76	0.4	
	NF-VNMX160408	-	-	-	●			0.8	
	NF-VNMX160412	-	-	-	●			1.2	
	VNMX160404	-	-	-	●	9.525	4.76	0.4	
	VNMX160408	-	-	-	●			0.8	
	VNMX160412	-	-	-	●			1.2	

Dog bone insert type

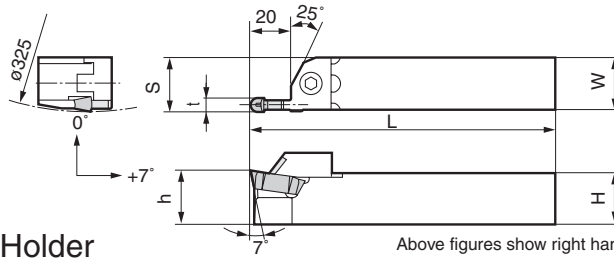
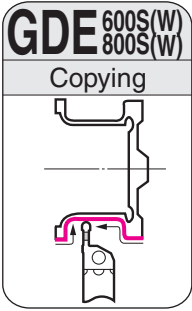

Holder

Above figures show right hand tools.

Sumitomo Cat. No.	Stock		Dimensions (mm)						Clamp with carbide piece	Steel Clamp	Screw	Wrench
	R	L	H	W	L	S	h	t				
◆ GDE R/L2525-600S	●	●	25	25	150	26	25	6	—	GDS600R/L	BX0625	LH050
◇ GDE R/L2525-800S	●	●	25	25	150	26	25	8	—	GDS800R/L		
◆ GDE R/L2525-600W	●	●	25	25	150	26	25	6	GDW600R/L	—		
◇ GDE R/L2525-800W	●	●	25	25	150	26	25	8	GDW800R/L	—		

Parts

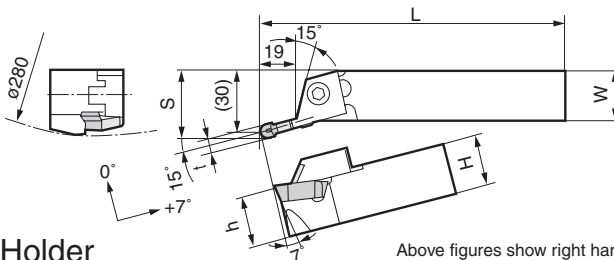
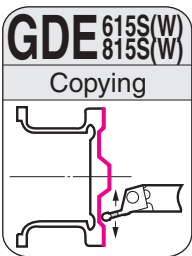
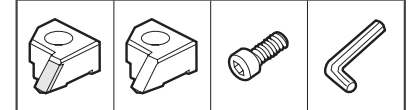

Holder

Above figures show right hand tools.

Sumitomo Cat. No.	Stock		Dimensions (mm)						Clamp with carbide piece	Steel Clamp	Screw	Wrench
	R	L	H	W	L	S	h	t				
◆ GDE R/L2525-615S	●	●	25	25	150	32.2	25	6	—	GDS615R/L	BX0625	LH050
◇ GDE R/L2525-815S	▲	▲	25	25	150	33.2	25	8	—	GDS815R/L		
◆ GDE R/L2525-615W	●	●	25	25	150	32.2	25	6	GDW615R/L	—		
◇ GDE R/L2525-815W	▲	▲	25	25	150	33.2	25	8	GDW815R/L	—		

◆: For nose radius 3.0 insert. ◇: For nose radius 4.0 insert.

Parts

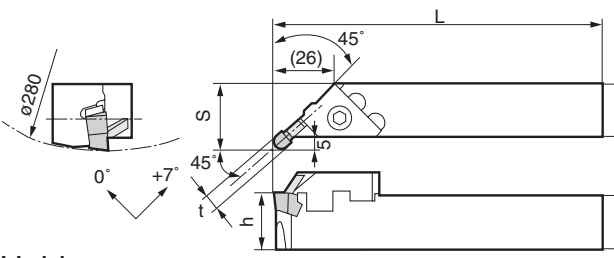
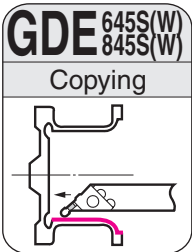
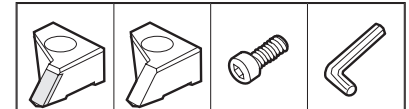

Holder

Above figures show right hand tools.

Sumitomo Cat. No.	Stock		Dimensions (mm)						Clamp with carbide piece	Steel Clamp	Screw	Wrench
	R	L	H	W	L	S	h	t				
◆ GDE R/L2525-645S	●	●	25	25	150	30	25	6	—	GDS645R/L	BX0625	LH050
◇ GDE R/L2525-845S	▲	▲	25	25	150	30	25	8	—	GDS845R/L		
◆ GDE R/L2525-645W	▲	▲	25	25	150	30	25	6	GDW645R/L	—		
◇ GDE R/L2525-845W	▲	●	25	25	150	30	25	8	GDW845R/L	—		

◆: For nose radius 3.0 insert. ◇: For nose radius 4.0 insert.

Parts

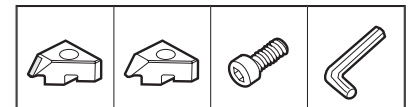

■ Insert (Coated/ Carbide/ SUMIDIA)

● Dog bone type

Shape	ISO Cat. No.	Stock				Dimensions (mm)			Applicable Toolholder
		EH10Z	G10E	H1	DA2200	Inscribed circle	Thickness	Nose radius	
	MDE3R-AW			●	—	26	8.5	3.0	◆
	MDE4R-AW			●	—	30	8.5	4.0	◇
	MDE3R	—	—	—	●	26	8.5	3.0	◆
	MDE4R	—	—	—	●	30	8.5	4.0	◇
	MDE3R-AW	—	—	—	●	26	8.5	3.0	◆
	MDE4R-AW	—	—	—	●	30	8.5	4.0	◇