



# Horizontal/Vertical Rotary Table



HV-6, 8, 10, 12, 14, 16

## Special Accessories (Details on page 2)



**NEW**

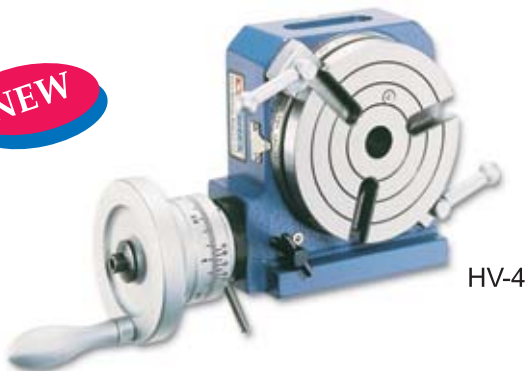

HV-4

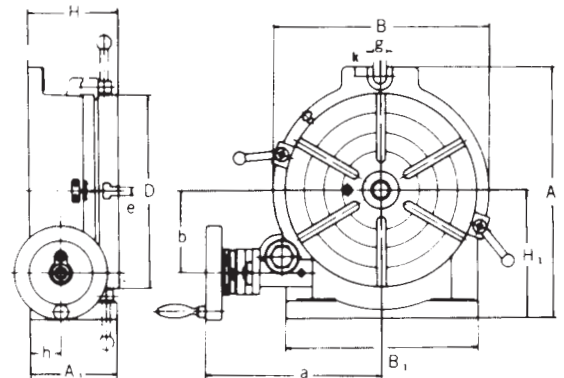

Unit:mm/inches

## Order No. & Dimensions

ORDER NO.	Table			Base dimension			Width of T-slot		Bolt slots	Center sleeve	Gross Weight kg/lb wooden case(W) Caron(C)	Meas. CFT	CODE NO.
	Outer diameter		Height	H1	A	B	e	Type					
	A1	D	H										
<b>HV-4</b>	70	110	80	85	145	115	11	⊕	12	MT-2	(C) 7.5	0.3	1001-000
<b>HV-6</b>	78 3.07	150 5.91	80 3.11	100 3.94	200 7.87	160 6.30	11 0.43	⊕	15 0.59	MT-2	(C) 13	0.4	1001-001
<b>HV-8</b>	100 3.94	200 7.87	105 4.13	135 5.31	265 10.43	220 8.66	14 0.55	⊕	17 0.67	MT-3	(C) 26	0.8	1001-002
<b>HV-10</b>	110 4.33	250 9.84	115 4.53	165 6.50	325 12.80	280 11.02	14 0.55	⊗	17 0.67	MT-3	(C) 37	2	1001-003
<b>HV-12</b>	130 5.12	300 11.81	135 5.32	195 7.68	388 15.27	330 12.99	16 0.63	⊗	18 0.71	MT-4	(W) 70	2.6	1001-004
<b>HV-14</b>	130 5.12	350 13.78	140 5.51	230 9.06	450 17.72	380 14.95	16 0.63	⊗	18 0.71	MT-4	(W) 93	3.2	1001-005
<b>HV-16</b>	150 5.90	406 15.98	155 6.10	255 10.03	500 16.69	430 16.93	16 0.63	⊗	18 0.71	MT-4	(W) 122	4.2	1001-006

1. Table is made of high density Meehanite and use "HEIDENHAIN" electronic equipment to inspect angle to assure the excellent quality and durability.
2. Use excellent machining center to process. Spindle end be applied accuracy bearing. Can be assured to keep very steady under load cutting.
3. Worm is hardened and ground. The ratio is 90:1. The work table is graduated a full 360° so that one turn of the handle moves the table through 4°. Micro collar is graduated in steps of 1' min. And vernier scale makes settings down to 10 seconds possible.
4. These Rotary Tables are popular for their excellent performance, practical design and reasonable cost. they are widely used for circular cutting work, angle setting, boring, spot-facing and similar work.
5. Used the Key guide block, the center can be corrected both quickly and accurately.

## Test Report

ITEM NO.	TESTING OBJECTIVE	VARIATION(INCHES)(MM) MAXIMUM TESTED
1	FLATNESS OF CLAMPING SURFACE(CONCAVE)	.0006(0.015)
2	PARALLELISM OF CLAMPING SURFACE TO BASE	.0008(0.02)
3	SQUARENESS OF CLAMPING SURFACE TO ANGLE FACE	.0008(0.02)
4	TRUE RUNNING OF CLAMPING SURFACE	.0006(0.015)
5	TRUE RUNNING OF CENTER HOLE MEASURED AT HOLE EDGE	.0008(0.02)
6	INDEXING ACCURACY OF DIRECT INDEXING MECHANISM MAXIMUM CUMULATIVE SPACING ERROR	45"