



Semi-Universal Dividing Head



ORDER NO.	WEIGHT	CODE NO.
BS-0	20kgs	1001-050
BS-1	33kgs	1001-051

Standard Accessories



**THREAD SPINDLE: BS-0. 1½ -8TPI
BS-0. 1½ -8TPI**

Dividing Plate A,B,C

Numbers of hole	Plate A	15	16	17	18	19	20
	Plate B	21	23	27	29	31	33
	Plate C	37	39	41	43	47	49

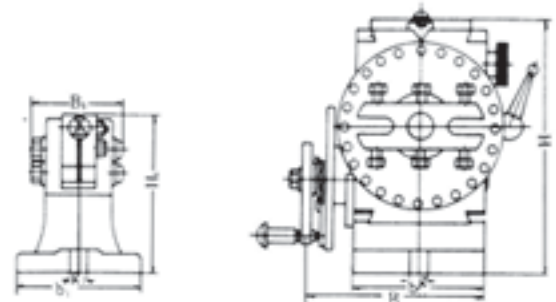
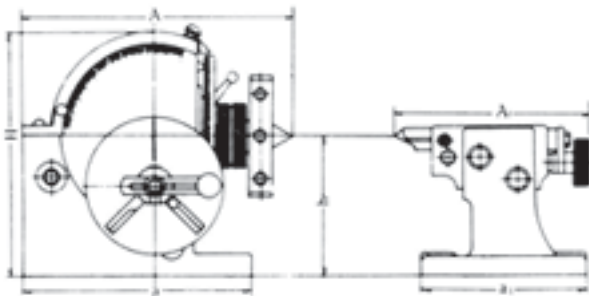

Semi-Universal Index B & S Type
No.0 No.1(Head-stock):

Unit:mm/inches.

ORDER NO.	A	B	H	h	a	b	g	TAPER OF CENTER	Diameter of spindle hole
BS-0	189 7 7/16	140 5 23/64	173 6 13/16	100 3 19/16	160 6 19/64	91 3 37/64	13 33/64	MT-2	18
BS-1	293 11 17/32	156 6 9/64	220 8 21/32	128 5 3/64	207 8 5/32	114 4 31/64	16 5/8	MT-3	20

Semi-Universal Index B & S Type
No.0 No.1 (Tail-Stock):

Unit:mm/inches

ORDER NO.	A1	B1	H1	h	a1	b1	g1
BS-0	167 6 37/34	80 3 5/32	107.5 4 19/64	100 3 19/16	130 5 1/8	92 3 2/8	13 33/64
BS-1	191 7 33/64	88 3 15/32	137 5 25/64	128 5 3/64	150 5 29/32	108 4 1/4	16 5/8

1. Dividing Head can divide in any angle by the direct, indirect, or different methods. The ratio between the worm and the worm gear is 40:1.
2. Hardened and ground spindle is rigidly held in a taper roller bearing. Worm is hardened and ground also.
3. The swivel head can be locked of any angle from 10° below horizontal to 90° vertical-precision fitting to base assures smooth rotation.
4. All models have threaded spindle nose and 24 hole dividing plate with easy conversion to fast direct indexing on numbers 2, 3, 4, 6, 8, 12, and 24.
5. Easy indexing of all numbers from 2 to 50 and many numbers from 52 to 380. Model BS-2 is also equipped for different indexing of all numbers from 2 to 380, and for spiral cutting.
6. Accurate precision, little backlash, fine appearance and strong structure so can assure smooth rotation.



**The state of
BS-0 fitted with 5" 3-Jaw Chuck**